

AM · FM · TELEVISION

# BROADCAST NEWS



VIDEO SWITCHING WITH REMOTE RELAYS ... See Pg. 67



IT'S UNOBTUSIVE. Umber gray coloring blends it right into the TV picture. Minimum reflection.

## In the show . . . without stealing the act

RCA's new ribbon-pressure **"STARMAKER"\***

SO SLIM YOU MUST LOOK sharply to see it . . . so skillfully styled its shape and coloring fade right into the scene . . . this tubular microphone has won the favor of entertainers and announcers wherever it has been shown.

Designed by RCA Laboratories after more than three years of painstaking research, the STARMAKER meets the long need of broadcasting, television, and show business for a high-fidelity microphone that—will not hide the features of performers—is easier to handle—and yet retains all the high-quality features of RCA professional microphones. Pick-up is non-directional. Frequency response is uniform, 50 to 15,000 cps.

Here is a "carry-around" microphone free from wind blast and air rumble. It contains no tubes, no condensers, no high-impedance circuits, no special amplifiers, or power supplies—is virtually impervious to mechanical shock.

The STARMAKER fits any standard microphone stand . . . and can be substituted for any professional high-quality RCA microphone. *No extra attachments needed!*

For price and delivery, call your RCA Broadcast Sales Engineer. Or write Dept. 7K, RCA Engineering Products, Camden, N. J.

*\*Selected from entries submitted by Broadcast Stations in national contest.*



IT'S COMFORTABLE TO HANDLE . . . weighs only 1 lb.

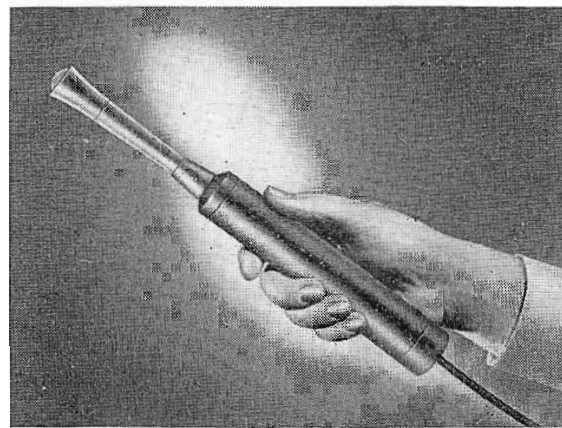

IT'S SMALL. Diameter of body is only 1¼ inches. Diameter of pick-up point is only ⅜ inch!



**AUDIO BROADCAST EQUIPMENT**  
**RADIO CORPORATION of AMERICA**  
**ENGINEERING PRODUCTS DEPARTMENT, CAMDEN, N. J.**

In Canada: RCA VICTOR Company Limited, Montreal

# Broadcast News

AM • FM • TELEVISION

Published by the

RADIO CORPORATION OF AMERICA

ENGINEERING PRODUCTS DEPARTMENT . . . CAMDEN, NEW JERSEY

NUMBER 61

September-October, 1950

### Subscription Rates

In continental U. S. A. - \$4.00 for 12 issues

In other countries . . . \$5.00 for 12 issues

JOHN P. TAYLOR, Editor

JUDY A. SEIGLE, Ass't Editor

W. O. HADLOCK, M. L. GASKILL, E. B. MAY, Associate Editors

## Contents

WBSM, WBSM-FM . . . . .	by OTTO F. A. ARNOLD	8
FLYING SPOT CAMERA, TYPE TK-3A . . . . .	by C. R. MONRO	16
WKPT, WKPT-FM . . . . .	by THOMAS PHILLIPS	22
TEST AND ALIGNMENT PROCEDURES FOR VIDEO AMPLIFIERS by F. E. CONE AND N. P. KELLAWAY		28
THE REQUIREMENTS OF TELEVISION STATION DESIGN by DR. WALTER J. DUSCHINSKY		34
EMPIRE STATE TELEVISION . . . . .		41
WOR-TV STUDIOS . . . . .	by NEWLAND F. SMITH	46

Copyright  
Radio Corporation of America  
RCA Victor Division  
Camden, N. J.

PRINTED  
IN  
U. S. A.

**OUR COVER** for this issue is designed to illustrate a new and important trend in TV system design; namely, the use of remotely-controlled relays in video switching circuits. The background picture shows part of a bank of video relays, while the inset picture shows the master control position from which these d-c operated relays are push-button controlled. These illustrations are reproduced from Kodachromes made at WOR-TV by our staff photographer, Rod Allen.

**VIDEO SWITCHING RELAYS** of the type shown in the illustration on the cover were first described in an article by W. E. Tucker and C. E. Monroe, of our Television Terminal Engineering Group in the March-April 1950 issue (Vol. No. 58) of BROADCAST NEWS. Previous to this time practically all video switching was accomplished by means of mechanically-operated push switches located directly in the video lines. Such an arrangement was (and still is, for that matter) fairly satisfactory when not more than six input and two output positions are involved. However, for more complex installations the size of the control position becomes unwieldy—mainly due to all the coax connections which must be brought up to the mechanically-operated switches.

The use of relay-operated video switches overcomes these limitations. Such switches may be located at whatever point is best from the viewpoint of the video circuit installation—and their operation controlled by simple d-c lines from whatever point (such as the director's console) that is most convenient from the production viewpoint. Even more important, they may, if desired, be controlled from more than one point—thereby making possible such features as "preset" operation, interlocked audio and video switching, multiple control room operation of the same cameras, etc.

It is interesting to note that the relation of mechanically-operated to relay-operated switching in video systems is analogous to the situation with respect to audio system installations. In audio we have learned, over the years, that mechanically-interlocked switching, such as used in most audio "consolettes", is satisfactory for most small and some medium-sized installations—but that for larger independent stations, and most network originating stations, a more flexible relay-operated system is necessary. The evolution of TV station design is obviously tending in the same direction.

The reason we bring all this up now is not only to emphasize this important trend, but also because the WOR-TV installation, featured in this issue, is the first large-scale operation of the relay-operated type which we have presented in BROADCAST NEWS. In the article which begins on Page 46 the facilities of WOR-TV are described at some length—particularly the flexibility of the installation. A number of the facilities combinations which this flexibility makes possible are also described—somewhat more briefly. The assumption is made that the reader is fairly familiar with the idea of the remote-controlled relay type operation. Since this may not always be the case, we suggest that those wishing to study the WOR-TV operations in detail may benefit by going back and reading the Tucker-Monroe article referred to above.

**WOR-TV INSTALLATION** described in the article beginning on Page 46 is notable not only because it is the first large-scale relay-operated installation (see above), but also in several other respects. One of these is that from the equipment viewpoint it is probably the largest independent station installation made to date. Another is the fact that all camera control units are grouped together at a central location—rather than being scattered in individual control rooms. Still a third—and particularly interesting to us—is the fact that much of this installation was planned by Newland Smith, formerly head of our TV Systems Engineering Group. "Smitty" is mighty proud of WOR-TV—and so are we. Partly because of this pride—and partly because it has so many interesting features—we've given WOR-TV a preponderant amount of space. If it slightly overbalances this issue, we hope you'll forgive us.

# SOUND TRANSLATION.

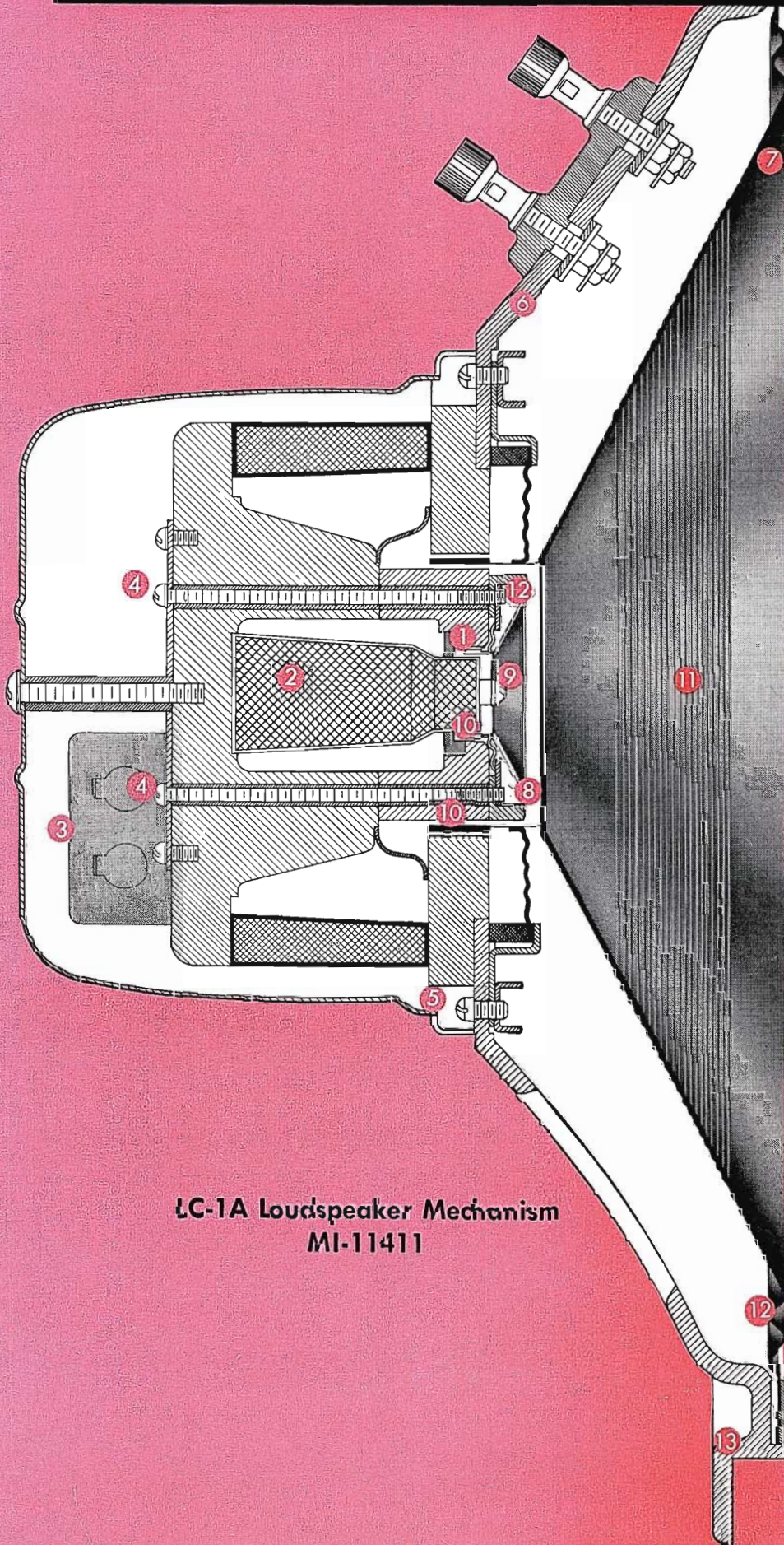

LC-1A Loudspeaker Mechanism  
MI-11411

1 H-f voice coil, aluminum wire-wound, to deliver full h-f range

2 Heavy ALNICO V magnets

3 Cross-over condenser

4 Centering adjustment for h-f cone

5 Centering adjustment for l-f cone

6 Sturdy die-cast aluminum frame

7 Shallow cone for smooth response and greater angle of distribution

8 H-f and l-f cones coaxially-mounted, mechanically independent

9 H-f cone. Diaphragm diameter only 2 $\frac{3}{8}$ ". Wide-angle distribution to 15,000 cycles

10 Ample gap clearances

11 Massive 15" l-f cone. Bass response 35 to 2000 cycles at all volume levels

12 Cone rim treated to minimize edge reflections for smoother response

13 Offset mount eliminates front cavity —insures smooth response

..... **next to perfect!**

## The Famous LC-1A Speaker

Among the great achievements of the RCA Princeton Laboratories is the development of the most advanced speaker in the world—the RCA Duo-Cone, Type LC-1A.

Expressly designed to give sound its true translation, this professional speaker is matched by no other high-quality sound reproducer.

Unique duo-cone design (originated by Dr. H. F. Olson of RCA Princeton Labs) provides a smooth response from 50 to 15,000 cycles—with no resonant peaks, harmonics, or transient distortion. Full power is radiated over 120-degrees at 15,000 cycles—makes it possible to enjoy high-fidelity sound *any place in the room!* Smooth crossover response around 2000 cycles eliminates all undesirable interference between the high-frequency unit and the low-frequency unit. Controllable “roll-off” at 5 and 10 kc... when used with the MI-11707 filter... restricts the h-f distortion and surface noises present in many recordings.

Today, more than 3000 of these speakers are serving in station control rooms, listening rooms, auditioning booths, lobbies, clients' offices, and private homes.

For more information, mail the coupon.



**AUDIO BROADCAST EQUIPMENT**  
**RADIO CORPORATION of AMERICA**  
ENGINEERING PRODUCTS DEPARTMENT, CAMDEN, N. J.

In Canada: RCA VICTOR Company Limited, Montreal

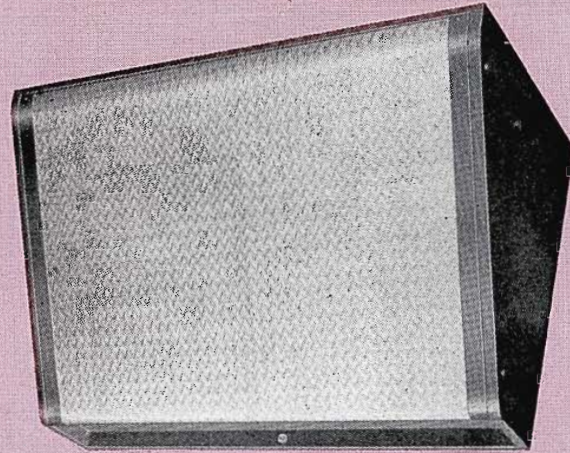

### New Wall-Ceiling Housing for LC-1A

Ideal for sound reinforcement in control rooms, auditioning booths, hallways, talkback positions, elevators,

executive offices. Port provided for increasing bass response. Finished in harmonizing 2-tone umber gray.

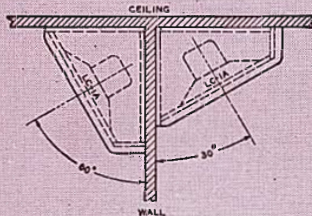

### It's Easy to mount

The Wall-Ceiling Housing can be mounted for long or short “throws”—makes the wall and ceiling a part of the acoustical system.

### The LC-1A Monitoring Speaker, with Console cabinet and MI-11707 filter

The finest reproducer in the business. Available in a choice of 2-tone umber gray or walnut finish.

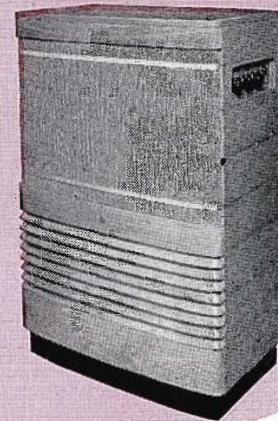

Department 19-IC,  
RCA Engineering Products  
Camden, N. J.

Send me price and information on

- LC-1A Speaker Mechanism, MI-11411
- LC-5A Wall-Ceiling Cabinet, MI-11406
- LC-1A Speaker with Console Cabinet, MI-11411/11401

Name \_\_\_\_\_

Station or firm \_\_\_\_\_

Address \_\_\_\_\_

City \_\_\_\_\_ State \_\_\_\_\_

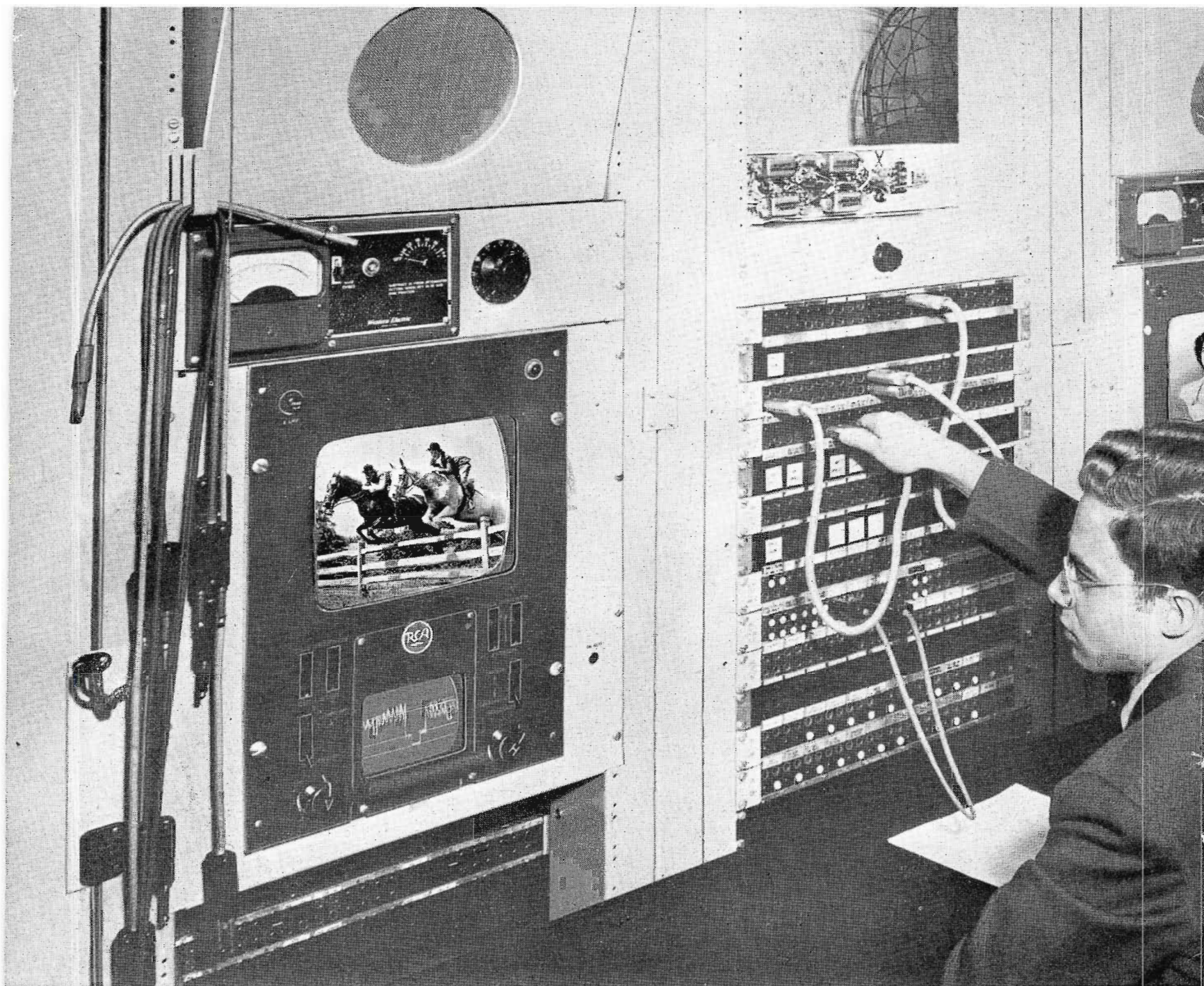

# ***THE BELL SYSTEM'S TV NETWORKS***

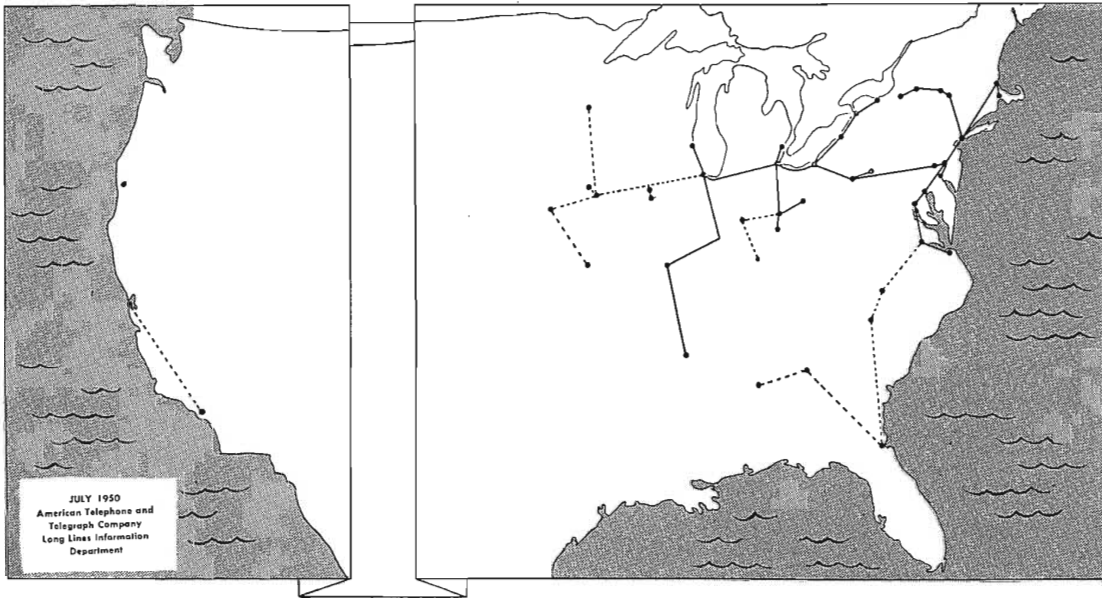

## **Bell System TV Network Routes**

——— IN SERVICE  
 - - - - PLANNED FOR 1950



JULY 1950  
 American Telephone and  
 Telegraph Company  
 Long Lines Information  
 Department



MONITORING POSITIONS in the new TV network control center at the headquarters building of the Long Lines Dept., A. T. & T. Co., New York. Video and sound equipment at each position provide finger-tip control of the network channels interconnecting Manhattan's studios with Bell System's inter-city TV networks. The picture monitors are RCA!

## **-use 44 RCA Picture Monitors!**

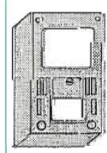

RCA Picture Monitor, TM-5A. Provides complete supervision of composite picture signals at every stage of video transmission.

12 in New York, 8 in Philadelphia, 1 in Detroit, 3 in Baltimore, 4 in Boston, 5 in Chicago, 1 in Buffalo, 6 in Washington, 2 in Albany, 1 in Toledo, 1 in Milwaukee.

And the Bell System is moving right ahead. By the end of 1950, network routes will include 15,000 TV-channel miles—reach more than 40 cities—provide TV program facilities to areas with populations adding up to 57,000,000 people!

RCA takes pride in supplying many of the picture

monitors for this vast network of coaxial lines and radio relays—the system that makes network television practicable.

When *you* get ready to expand your operations, look to RCA for everything in the "specs"—complete station studios, fully-equipped transmitter rooms, film projector rooms, all field equipment gear, entire control rooms, "tailored" antenna systems.

Your RCA Broadcast Sales Engineer is at your service. Call him. Or write Dept. 19-IA, RCA Engineering Products, Camden, New Jersey.



**TELEVISION BROADCAST EQUIPMENT**  
**RADIO CORPORATION of AMERICA**  
**ENGINEERING PRODUCTS DEPARTMENT, CAMDEN, N. J.**

In Canada: RCA VICTOR Company Limited, Montreal

# America's Key Network Stations Use RCA TV Equipment... *WNBT for instance*

**O**N THE AIR LONGER than any other TV station in the New York metropolitan area, this key network station of the National Broadcasting Company is setting a record for on-air time—with more than 312 hours of local and network transmission a month to a potential audience of 1½ million families.

Well-known in the business for its high-quality programming . . . and technical excellence of operation . . . we are proud that WNBT is supported by RCA television equipment *throughout the station!*

For instance, a complete transmitter room—with all associated equipment. Everything in field equipment—including microwave relays. Film projection equipment. Remote video relay switching. Studio control room equipment. Control consoles, amplifiers, projection changeovers, synchronizing generators, power supplies, etc.

When you face up to the job of planning your TV station . . . or add on facilities to your operations . . . select the same equipment the key network stations use. *Go RCA!*

Your RCA Television Equipment Sales Engineer is at your service.

From camera lens to antenna—everything in WNBT is RCA! ▶

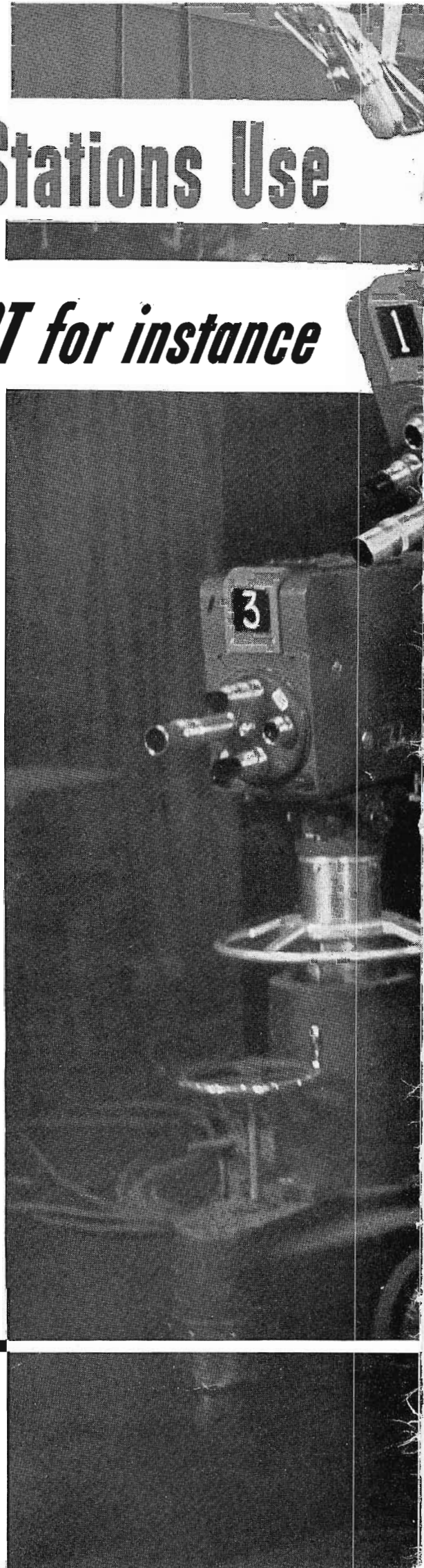





TELEVISION BROADCAST EQUIPMENT  
**RADIO CORPORATION of AMERICA**  
ENGINEERING PRODUCTS DEPARTMENT, CAMDEN, N. J.

In Canada: RCA VICTOR Company Limited, Montreal

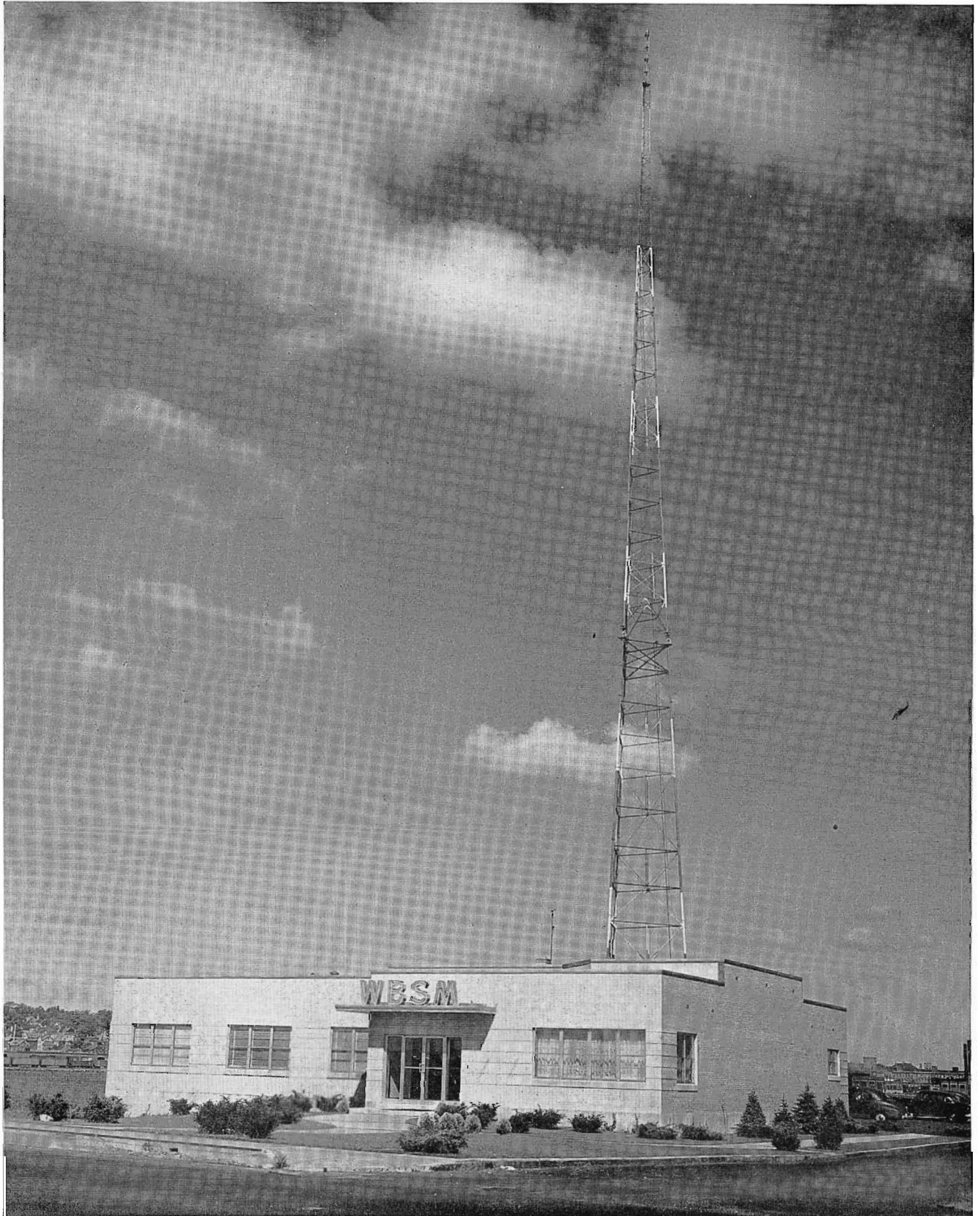

WBSM, WBSM-FM transmitter-studio building and antenna tower. The tower is some 200 feet behind the building (See opposite page.)

Air view of Pope's Island and part of New Bedford. The WBSM transmitter building and antenna (left center) are entirely surrounded by the salt water of Buzzards Bay.



# WBSM, WBSM-FM NEW BEDFORD MASSACHUSETTS

by OTTO F. A. ARNOLD, Manager and Technical Director

"It's beautiful and so pleasant and roomy, but I never expected to find so much in a building this size." This statement by the majority of the WBSM visitors describes what the author and the Bay State Broadcasting Company were trying to accomplish when the plans for WBSM were being formulated. The operation was initiated by WBSM-FM with effective radiated power of 20,000 watts on February 22, 1949, and was followed in July by WBSM, which operates on 1230 kc., 100 watts, unlimited.

Both stations operate full-time in a combined studio and transmitter building

located on Pope's Island, in New Bedford, Mass. This island, surrounded by salt water, is strategically located one-quarter mile east of the business center and linked to it by a four-lane highway which crosses the island and continues to Fairhaven, a suburban area of great importance to the New Bedford market. The station is very satisfactorily serviced by surface transportation, and large parking facilities are available for the staff, talent, or visitors, hence eliminating one of the major problems confronting an operation in the center of the city.

As an independent station with emphasis on local programming, and eighteen hours of programs to prepare and produce daily, it was obvious that efficiency of operation was of prime importance rather than false economy in design of the plant. It was decided that the wisest course would be to satisfy every reasonable need for space and arrive at the optimum design.

Once the space requirements were established, there remained the task of producing a functional layout. A preliminary floor plan was drawn and subjected to the criticism of other station operators and the

RCA Functional Design Section, which produced many excellent suggestions. The floor plan was then given to the architects for the preparation of the detailed drawings.

Every effort was made in arriving at the detailed plans to keep the building completely functional and eliminate unnecessary "ginger." The floor plan demonstrates the results. The building was designed in sections for each department, with the sections placed in the order of work flow through the building. A client or visitor entering the building can be handled without causing distraction to the operating staff, whose efforts are mainly confined to the rear of the building. All talent and audience groups are confined to the lobby area or studios.

The program department is located in the rear-left section of the building. The music library is the center of the program departments' activities and all programs are prepared here. This room is provided with a table at which the scripts are prepared. The entire window wall is also used as a preparation area and provided with facilities for monitoring all types of records and transcriptions. Most of the remainder of the wall space, from floor to ceiling, is devoted to record storage. The programs, once prepared, are placed in racks with scripts and taken to the control room as a unit, providing the control engineer with all the material that he will need to air the show.

The control engineer is located in the center of the entire engineering section of

the building and has complete visibility throughout his area. The three studios are placed before him. All audio and monitoring equipment is on his left, the power-distribution panel and tower-light monitor on his right, and the two transmitters to his rear.

The right-rear corner of the building contains the shop, and provides complete facilities for the maintenance of the technical equipment and the building. It is provided with a loading platform for receiving and handling various shipments.

Adjacent to the business section and the program section is a lounge which contains a completely enclosed kitchen unit including a sink, stove, refrigerator and storage space for dishes and canned foods. This room has represented a great convenience to the entire staff and has received great use.

The entire building is air-conditioned year-round with the exception of the transmitter room. The building is divided into three zones which are separately controlled: the office section, the technical section less Studio A, and Studio A. This became necessary because of the weather exposure of the office section, and the large variation in the number of people using Studio A.

Three air-conditioning machines totalling eleven tons of refrigeration are required and are located in the Air-Conditioning and Heating Room at the rear center of the building. This room also contains a small furnace, a plenum chamber, two large recirculating fans, dehydrating equipment for the transmission lines, and the FM transmitter blower and high-voltage transformer. The two recirculating fans are used to remove heat from the transmitter room, which is exhausted in the summer and used to heat the entire build-

WBSM studio control room and transmitter room as viewed from studio A. Visible in the transmitter room is the RCA 10 KW FM transmitter, left, and RCA 250-watt AM transmitter, right. The audio racks are flush-mounted in the wall, facing the operator.

View behind the transmitters showing the AM and FM coaxial lines. In series with the FM line is the FM line monitor and the harmonic suppressor. Note the air exhausts located above the transmitters.



ing in the winter. This salvaged heat is more than adequate for this purpose and therefore relieves the furnace of all work except for hot-water supply. The air-conditioning room contains thirty-four operating and control motors which produce a great deal of noise and vibration, and for this reason, it is isolated from the rest of the structure and is on a separate foundation.

The studio facilities provided vary in size and acoustics to satisfy the conditions of the WBSM operation. Studio A is utilized for handling a reasonably large audience, or for large instrumental or vocal groups. The handy storage closet contains props and an adequate supply of folding chairs in roller stands which may be used

anywhere in the building. Studio B is ideal for speech purposes and was designed for smaller groups. Studio C is generally used for D.J. work, newscasting and most of the normal broadcasting. This studio is equipped with remote indicating meteorological instruments which provide instantaneous readings of such factors as temperature, wind direction and velocity, and barometric pressure. This, coupled with relative humidity and almanac information, is broadcast at regular intervals to the weather-conscious New England listener.

Complete visibility is afforded between all three studios, the control room and the recording room, which greatly eases the

normal production problems confronting an independent operation. These five rooms are acoustically treated to maintain quality and presence throughout. The studios are constructed directly upon a six-inch concrete slab which was poured on a four-inch vermiculite base. The walls directly around Studio C are bearing partitions, as are the outer walls of Studios A and B. These outer walls are hard-plastered on the outside, and coated with a vermiculite aggregate on the inside. The inner walls are supported on felt chairs from the floor and use cane-fibre sheets on the outer side, roll-type insulation in the wall, and the studio treatment as the interior surface. Wall materials exhibiting non-uniform transmission characteristics were used for



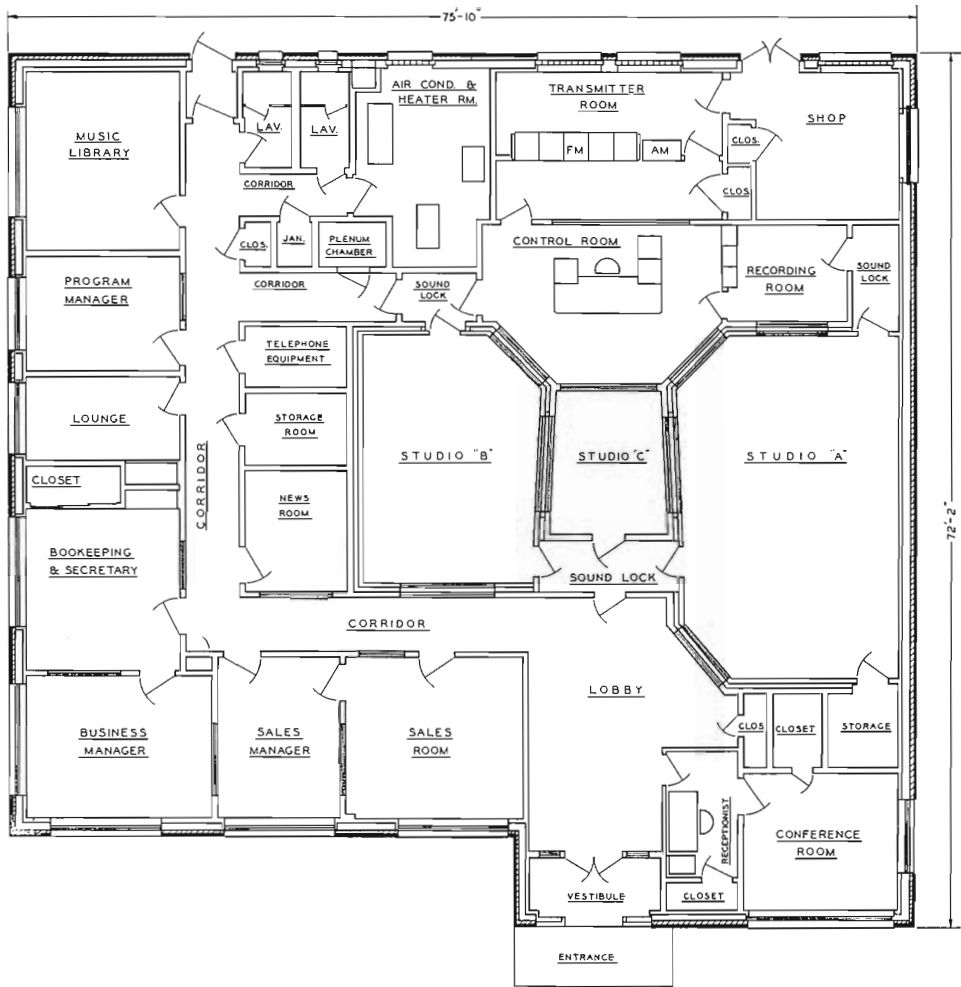

WBSM lobby viewed from the reception desk. ▶

◀ All transmitter and studio facilities of WBSM are contained in a single-floor building. The three studios and transmitter room are grouped about the one control room as shown in the floor plan.

Large windows in the control room shown below provide good visibility into all three studios. This photo was taken from the transmitter room. ▶





the same purpose as varying glass thicknesses in multi-glazed studio windows. No materials which are completely perforated were used in the building of these studios because of the necessity of establishing an additional barrier to avoid sound leaks with this type of construction. The ceilings are constructed in the same manner as the studio inner walls and are suspended from the roof rafters by a series of springs. Properly loaded they provide excellent isolation from the roof which is subjected to loud traffic noises and very low frequency boat whistles immediately adjacent to the building. All duct work is isolated from the studios by flexible couplings, and all other wiring is fed from the slab beneath the studios into the inner walls. Lighting fixtures are flush-mounted in the ceilings and surrounded by bulk asbestos insulation in boxes. The duct work feeding the entire studio section is lined throughout its length with absorptive material on the inside and thermal insulation on the outside.

The interior acoustical treatment of the studios employs polycylindrical diffusers, and splays, supplemented with partially perforated acoustical tile. The cylinders

were fabricated from  $\frac{1}{8}$ -inch poplar plywood in 4x4 sheets and mounted in the conventional manner, with batten joints. This departure from the normally accepted heavy masonry type construction has proven wholly adequate and represented a great reduction in the cost of construction.

Program requirements calling for split programs on AM and FM several hours a day necessitated a complete two-channel installation. The additional equipment and the necessary switching to change inputs and outputs as well as the studio and office monitoring facilities were provided. This was accomplished by installing a two-channel console on a custom-built desk in which many of the switching and control circuits were installed.

Three RCA Type 70-D turntables, modified for slow-speed records, operate in conjunction with this console. In order to minimize the use of the console preamplifier inputs, each turntable is fed through an RCA BA-2C preamplifier and then to an attenuator with a cueing switch. The latter feeds a separate monitoring amplifier located in the base of the control

table. These inputs are then combined by fixed pads and fed through a dynamic noise suppressor to the console turntable input. The control for the suppressor is also located at the control position to allow for variations in the quality of the recordings used. This method of utilizing the suppressor overcomes most of the objections that have been raised against the device, which certainly has demonstrated its value when used properly in conjunction with high-fidelity equipment.

The entire station is grounded to a single point, which is the ground radial system of the AM radiator. Eight of the radials terminate on a 5-inch sheet of copper, placed at the bottom of the trench system, through which all the power and audio wiring is distributed. All audio circuits are grounded at the console and each pair at this one point only. This arrangement had to be carried out to the last detail because of the extreme danger of cross-talk developing due to the proximity of the two transmitters to the audio equipment and the fact that the facilities carry separate programs at times.

*(Continued on next page)*



Studio B pictured during installation of acoustical treatment Roll insulation, the cylinder forms and fibre-covered cane ribs at right were covered with finished cylinders as shown at left.

The Recording Room is placed in such a position as to be readily accessible to the control room and Studio A, from which most of the recordings are made. The room is equipped with two tape-recorders, one of which is a small portable type frequently used for special events. This is supplemented by RCA disc-recording equipment and a communications receiver which is used for direct pickup of topical overseas broadcasts. Provision is made for a second disc-recorder, if needed.

The transmitter room houses the RCA BTA-250L AM Broadcast Transmitter and RCA BTF-10B FM Transmitter. A closet is provided in the transmitter room for all spare tubes and parts. All air entering the transmitter room is thoroughly filtered, thereby greatly reducing the maintenance problems. Both transmitters use air-dielectric coaxial lines to feed their respective antennas, the lines being pressurized with dry air. Both transmitters are equipped with instantaneous "arc-breakers" in the event of a flashover in either line.

#### Antennas and Transmission Lines

The antenna system consists of a 385 foot tower sectionalized at the 150 foot level by insulators for the AM radiator, and a two section FM antenna mounted aloft. The AM transmission line is coupled to the AM radiator by an RCA BPA-1A

Antenna Tuning Unit. The FM coaxial line crosses the base insulators without the use of an isolation unit. Isolation of the base of the AM radiator was accomplished by mounting on insulators the first 75 feet of FM transmission line on the tower and making a direct connection to the AM radiator at the 75 foot level. The short section of transmission line established by the FM coaxial line and the lower 75 feet of the AM radiator was then anti-resonated at the base of the tower to provide isolation.

This was done by measuring the base impedance with the FM transmission line disconnected, and then duplicating this impedance with the line connected by adjusting the anti-resonating capacitor. Another distinct advantage to this method of isolation is the fact that the various a-c lighting circuits were run across the base insulators without the necessity of installing lighting chokes. The a-c wiring is simply attached to the FM coaxial line and run up to the 75 foot level from which a spur feeds the side lights located on the AM radiator. The wires continue to cross the sectionalizing insulators in the same manner.

The problem at the 150 foot level is somewhat complicated by the fact that it is difficult to analyze such factors as coupling between the radiating and non-radiat-

ing portion of the structure. The isolating circuit used at the 150 foot level is electrically and mechanically identical to that used at the base of the tower but is physically inverted. However, in spite of the similarity of the two isolating circuits, the upper isolating capacitor cannot be set to the same value as the lower one because of the extraneous coupling that exists. It is necessary to detune the capacitor so as to eliminate radiation currents from the upper portion. The controlling factors for determining the effectiveness of isolation are the current distribution and the radiation efficiency. The base resistance, in itself, does not indicate isolation, as the base resistance of the lower 150 foot section of a 385 foot tower bears very little relation to the base resistance of a simple 150 foot tower of the normal variety. It is actually possible, in this type of structure, to produce a very substantial anti-phase current in the upper section of the tower, which would greatly reduce the station's coverage. The procedure for isolating the structure which finally proved effective was to vary the tuning capacitor over a substantial range on each side of the value determined for the base capacitor. For each setting of the capacitor, tower impedance, field intensity at several remote points, and the readings of R.F. ammeters located on the upper and lower portions of the tower were taken. The transmitter was



loaded to exactly 100 watts for each measurement, thereby necessitating an adjustment of the tuning unit for each measurement. The analysis of this data indicated that the correct current distribution was approached at a definite setting of the isolating capacitor and subsequent additional field intensity readings indicated that the radiation was reasonable, considering the extremely low attenuation in the salt water surrounding the station.

The ground system consists of 120 silver-plated No. 8 wires averaging 300 feet in length. The radials on land were plowed into the top-soil at varying depths to avoid getting into the cinder fill below, the entire area being reclaimed land. Some 50 of the radials go overboard and were

anchored at the ends by cement blocks. In order to protect them from ice damage where they leave the water, they were secured to the wooden sheathing of the bulkhead with battens. All joints to the expanded copper mesh screen were brazed to insure perfect contact.

In advance of the installation of the technical equipment, schematics were prepared which included every detail. These drawings have been maintained on a current basis and provide exact information as to the route of every pair of wires in the station. Each pair is marked with its number each place it appears. The diagrams also give terminal block numbers, rack numbers, and the specific connections made, thereby greatly reducing the effort

and time consumed when this information is required. Very adequate jack facilities are provided to make all inputs and outputs available for test purposes. When used in conjunction with the rack-mounted oscillator and the noise and distortion analyzer, any components responsible for the deterioration of audio quality can be rapidly isolated and repaired. Each member of the engineering staff performs routine preventive maintenance in accordance with an established schedule upon which all maintenance items appear at appropriate intervals. These procedures, coupled with excellent equipment, have enabled WBSM and WBSM-FM to maintain consistently high quality signals which have aided in rendering the best possible service to the community.

View into studio A. Recording room window is visible at the right beyond the piano, control room window (center), and studio C on the left.



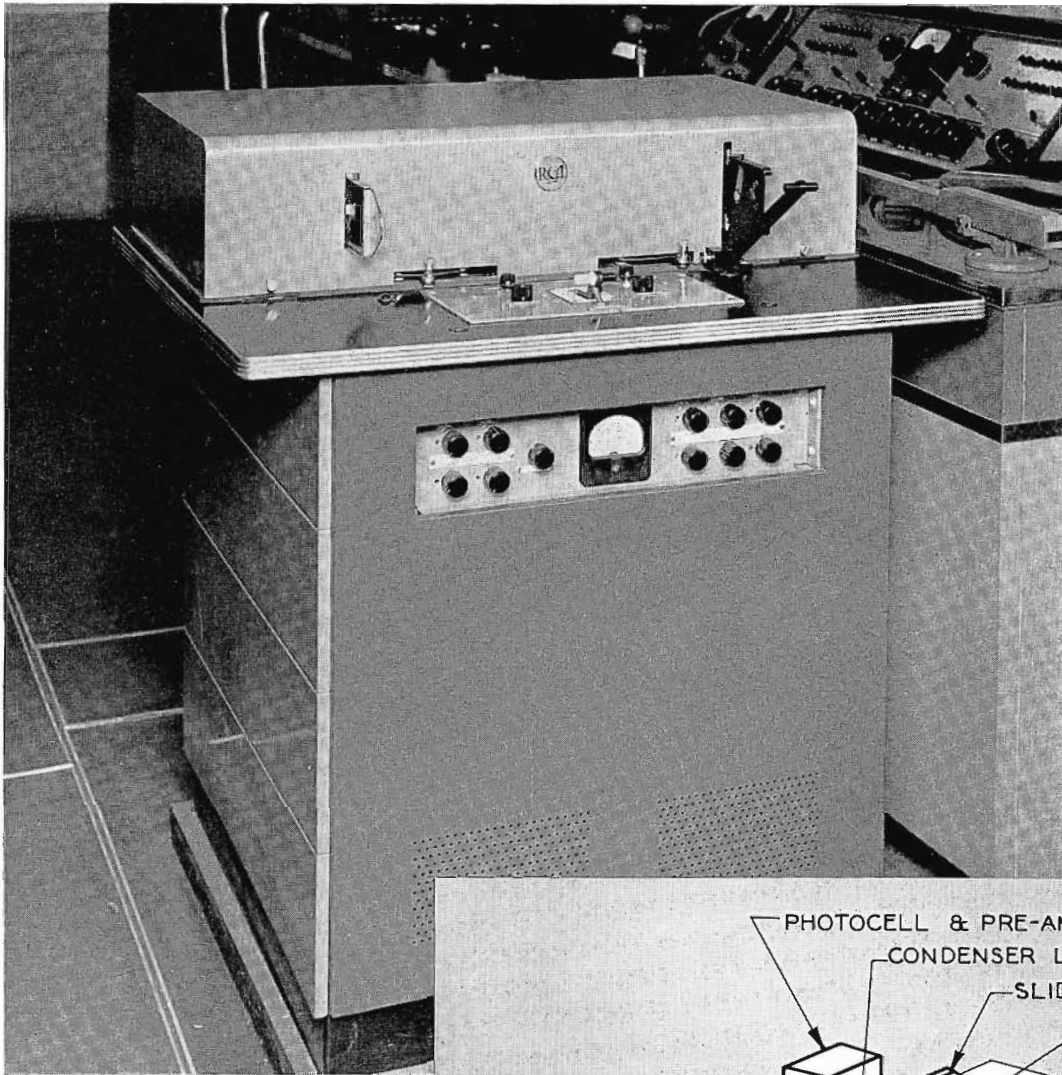

FIG. 1. Full view of the Flying Spot Camera, which is designed so that operating controls are at a convenient desk-top or turntable height. Note that in this and the succeeding photos the right-hand slide holder has been replaced by a Special Effects mask assembly which is supplied as an accessory.

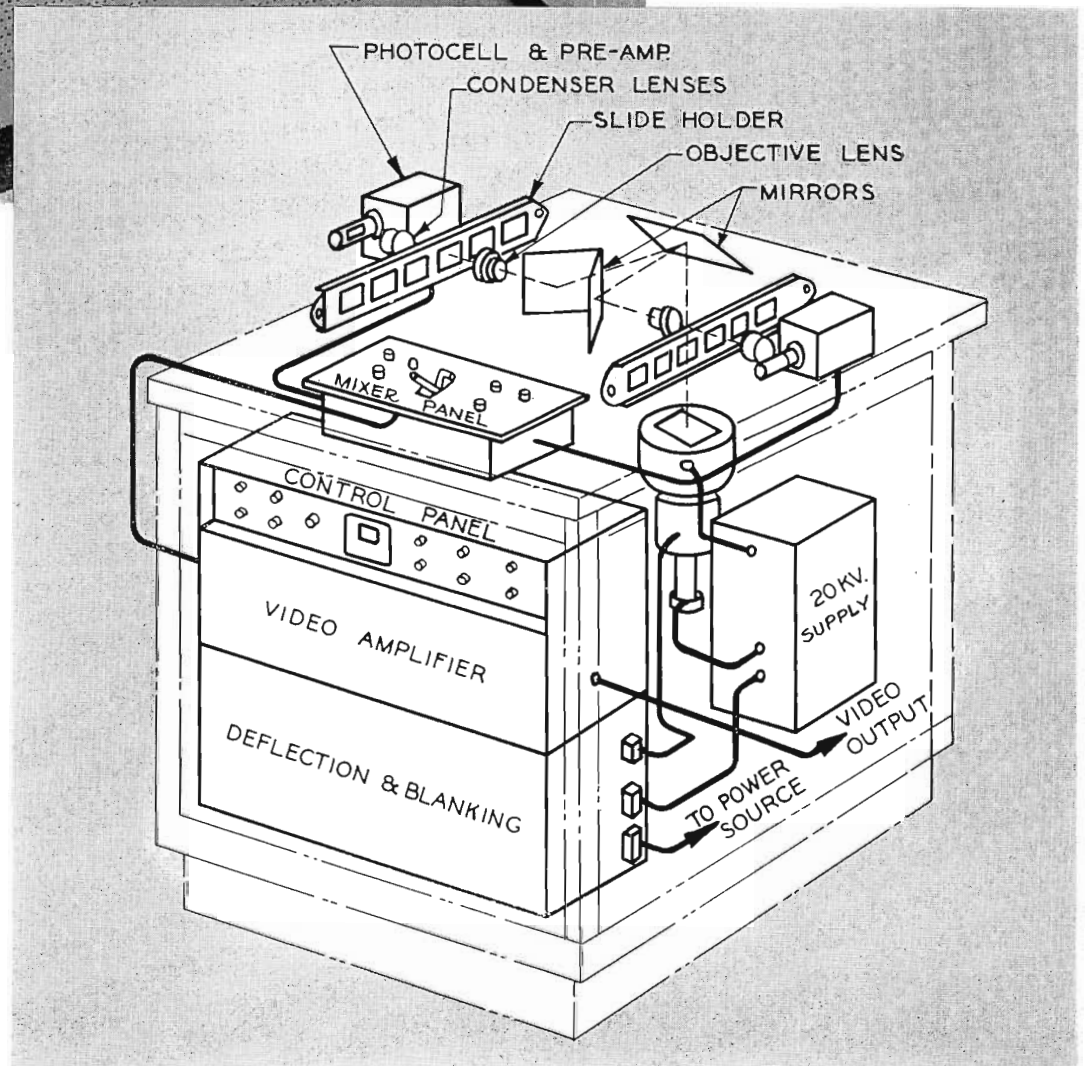

FIG. 2. Phantom sketch showing the location of various major components and circuit elements of the TK-3A. Heavy black lines denote circuit connections made between different stages.

# FLYING SPOT CAMERA, TYPE TK-3A

By C. R. MONRO

Television Terminal Equipment  
Engineering

## Introduction

In any television broadcasting activity considerable application is found for still subjects. These may be the simple pictures and titles which are used extensively for announcements and commercials, or they may be the test patterns which most stations transmit several hours a day. For these applications, the analogy to the familiar record turntable indicated a need for a television camera unit of comparable scope and application. Further, the field of use of this new picture source is not limited solely to TV broadcasting. The television laboratory and factory find use for fixed test signals and, in addition, will find the ability to change slides at will advantageous in testing equipment under more widely varying conditions than are possible with a single test pattern.

## Slide Size Considerations

The insertion of advertising material or station identification must be done quickly and smoothly, whether the material is a very short "Spot" announcement during station break or a full sequence of separate pictures. To accomplish this, the subject matter must be small and convenient to obtain and handle. Therefore, 2" x 2" slides were chosen as subject matter, after consideration of such factors as cost, ease of processing, and storage. The material to be presented, whether a live subject, an inanimate object, or a poster, is first photographed on 35mm film. Then either the negative or a positive print is mounted in a slide holder. From that point, there are no more problems of lighting or placement: the subject has been condensed into a form which meets the conditions set forth above for size and convenience.

## Camera Unit Considerations

The camera unit must be as simple as possible in its operation and adjustment. These factors, plus those of compactness and cost, led to the choice of the flying spot principle of picture generation instead of the more familiar iconoscope or image orthicon systems. This principle offers sev-

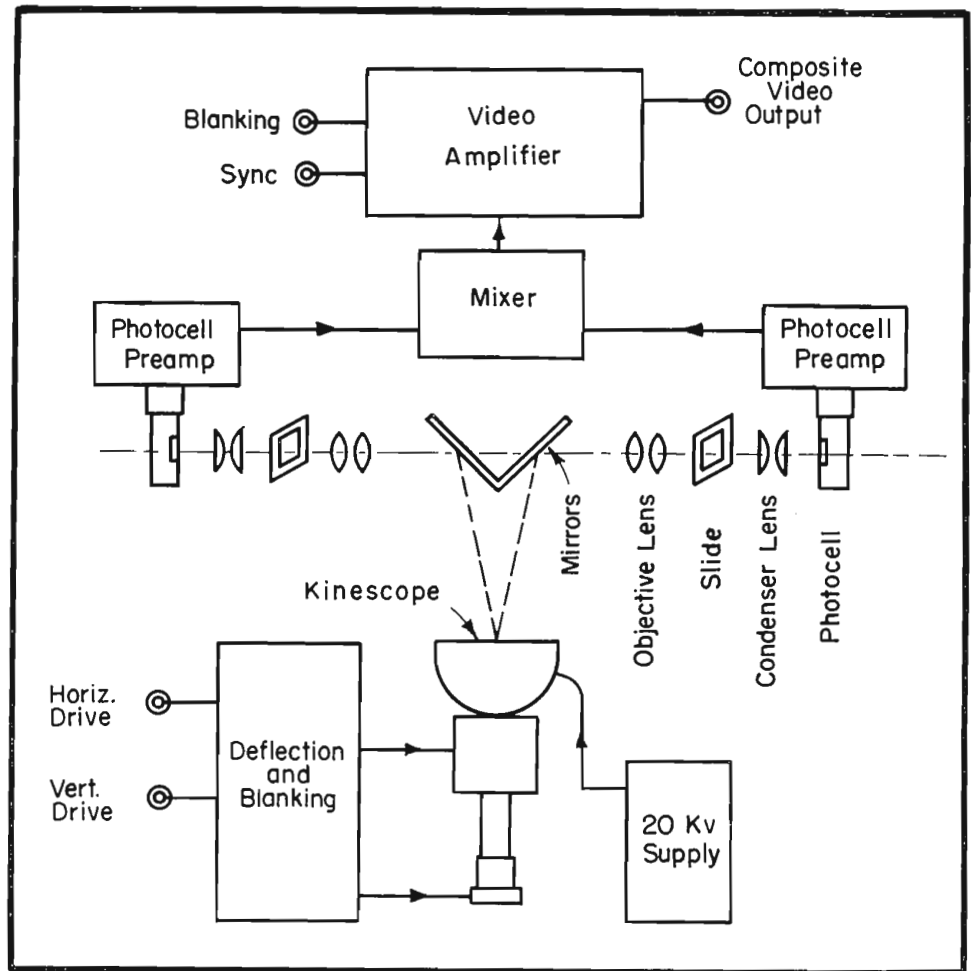

FIG. 3 (above). Simplified block diagram showing the various elements and the general operation of the Flying Spot Camera.

eral advantages which are particularly well-suited to the special needs of the subject matter proposed. These are, for example, excellent resolution and noise characteristics, freedom from picture burn-in effects, and relatively low cost.

## Theory of Operation

In describing the Flying Spot Camera it might be helpful to review briefly the theory which gives rise to its name. Strangely enough, it is an almost complete return to the same principles first used in the earliest history of commercial television. With the Flying Spot Camera (as was done in early television) a spot of light is made to move across, or scan, the object to be televised in an orderly manner which can be reproduced at the receiving end of the system. This spot of light is reflected, or passed on through (if

the object is transparent) in varying degrees according to the gray scale density of the object. To convert this light variation into a television signal requires only the use of a photocell, since the scanning has already been done.

The only basic difference between the early systems and the present "Flying Spot" system lies in the means of generating the scanning, or flying spot of light. Previously, a spirally perforated disc, or scanning wheel, was rotated in front of a steady source of light. A similar wheel, running in synchronism with the first, was used at the receiving end. Mechanical considerations, however, limited the usable definition to very coarse values because of spot size and wheel speeds. This limitation is overcome in the Flying Spot equipment by the use of a kinescope for the source of light.

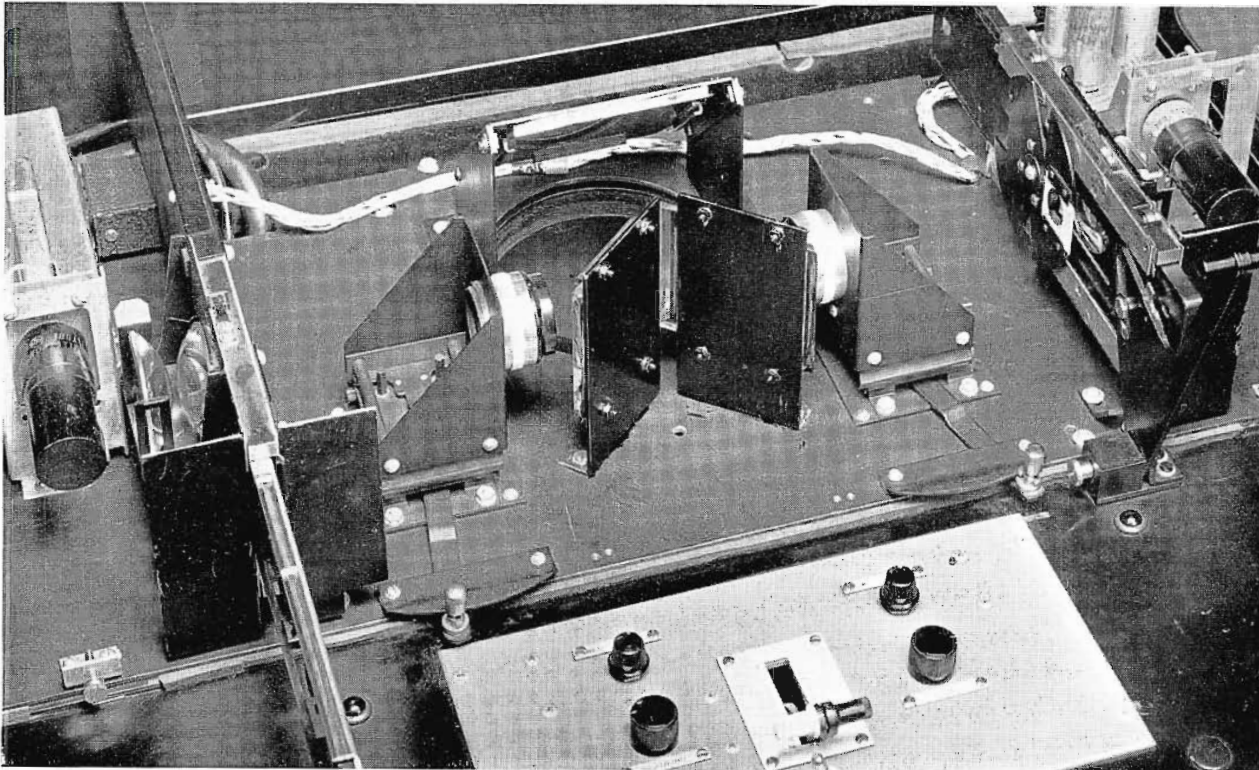

FIG. 4. Closeup view of Flying Spot Camera with top cover removed to illustrate the optical system employed.

To complete the analogy between old and new, the spot of light is the sharply focused spot on the phosphor of the kinescope face. The scanning wheel is replaced by deflection of the kinescope beam at standard television frequencies thus fitting the new system directly into commercial standards. A limitation of the new system appears in the kinescope, in that the light output from the kinescope phosphor limits the subject matter to relatively small size. Fig. 1 is a block diagram which outlines the various optical and electrical elements of the Flying Spot Camera.

#### Description

The complete Flying Spot Camera is illustrated in Fig. 2. As mentioned before, the basic idea of this project was to build a television equivalent of the familiar record turntable. The same convenient desk-top height is used and all of the often-used electrical controls are placed on top along with the slide changing and optical focus controls. The 5" kinescope is within the base cabinet, mounted towards the back, and in a vertical position. This way, all of the top area is available for the slides and lenses, and also maximum protection for the kinescope is afforded by its steel shield. This shield also contains

the 20 kv high voltage supply, permitting a very short second anode lead to the kinescope.

In programming where slide stills are to be shown in sequence or in conjunction with live subjects, it is very desirable to have smooth transition between individual pictures. In other RCA television studio equipment, this transition is accomplished very smoothly by means of manually-operated levers which permit either fading or superposition of two picture signals. To apply this useful scheme to the flying spot camera unit, an arrangement whereby two pictures may be obtained from the one kinescope is required. As shown in Fig. 3, this is accomplished with maximum light efficiency by the use of two mirrors placed above the kinescope so as to reflect the raster into two separate objective lens and slide carrier assemblies. Two photocells, with appropriate condenser lenses, are mounted behind the slide holders and their outputs fed to a mixer circuit controlled by the same type of fader levers mentioned above. Thus, as many as twelve slides may be shown without the annoying motion of slide changes being seen, if the slides are mounted in alternating sequence in two of the six-space slide holders illustrated in Fig. 4.

All of the remaining electronic circuits, including the video amplifier, control circuits and deflection circuits are contained in a standard "bathtub type" chassis which is in turn mounted on hinged rails in the front of the table cabinet. Tubes are accessible from the front, by removing the snap-on cover as shown in Fig. 5. Wiring is then seen by lowering the chassis until it is held parallel to the floor by stop-chains. This may be seen in Fig. 6.

The various controls needed for setup and occasional adjustment appear on this chassis. Those which might be needed from day-to-day, such as beam current, centering, size, etc., are mounted on a narrow panel at the top of the chassis and are accessible through an opening in the front cover. A meter which may be switched to read either kinescope beam current or high voltage is also located on this panel. Other controls, such as linearity and compensation, which are normally set and locked are located on the chassis itself.

All power connections to the main chassis and between this chassis and the mixer and pre-amplifier chassis are made with plugs to permit easy disassembly for service. All video connections are made through standard coax connectors.

### Control and Operating Features

The video operator need have no fear of a maze of controls, all requiring constant attention as various subjects are shown. First of all, the controls required for operation of the Flying Spot Camera are few in number and, in fact, most of them require only a check at the beginning of each operating day. For example, of the kinescope controls, only beam current and focus need attention and then only at setup time. Much can be done toward smooth operation by proper choice of the original material to be photographed and by processing slides which are to be shown in sequence so that they are of the same average density. The video gain controls will then require no adjustment during showing time.

The slide holder has been made very accurately so as to locate each slide exactly and consistently. Hence, if the slide mounts are all of one type, optical focus will remain the same for all slides. Either positive or negative slides may be accommodated by means of a polarity switch in the output of the mixer circuit which inverts the electrical signal.

Finally, in order to provide additional variety and flexibility, a selection is offered, by means of switches, of either lap dissolve, fading through black, instantaneous switching, or combinations of all three. A switch selects the use of either the fader mechanism or a toggle switch for transfer from one photocell output to the other. Also, the two levers comprising the fader mechanism may be operated together for lap dissolve, or separately for fading and superposition.

### Typical Applications

One need only to observe the operation of a typical television station to see many possible uses for the Flying Spot Camera. Test pattern is normally carried for many daytime hours, and is usually originated either in a monoscope with a special call letter kinescope or a slide projector and film camera. The Flying Spot Camera can supply this test pattern and in addition offer a variety of material for station call, commercials, or special occasions. In TV stations where film cameras are normally tied up for these operations, the addition of the Flying Spot Camera would free them for use in rehearsals, previewing, or maintenance. These considerations are probably most valuable in the studio, but would

FIG. 5. View of the two, "six-space" slide holders which allow twelve slides to be shown in succession.

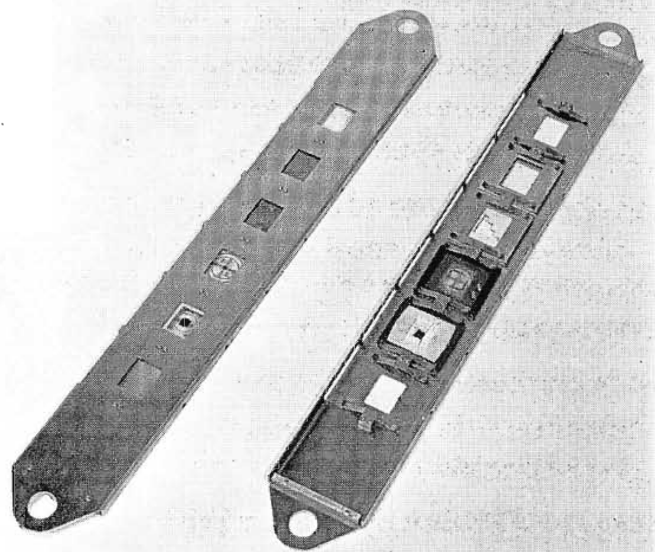
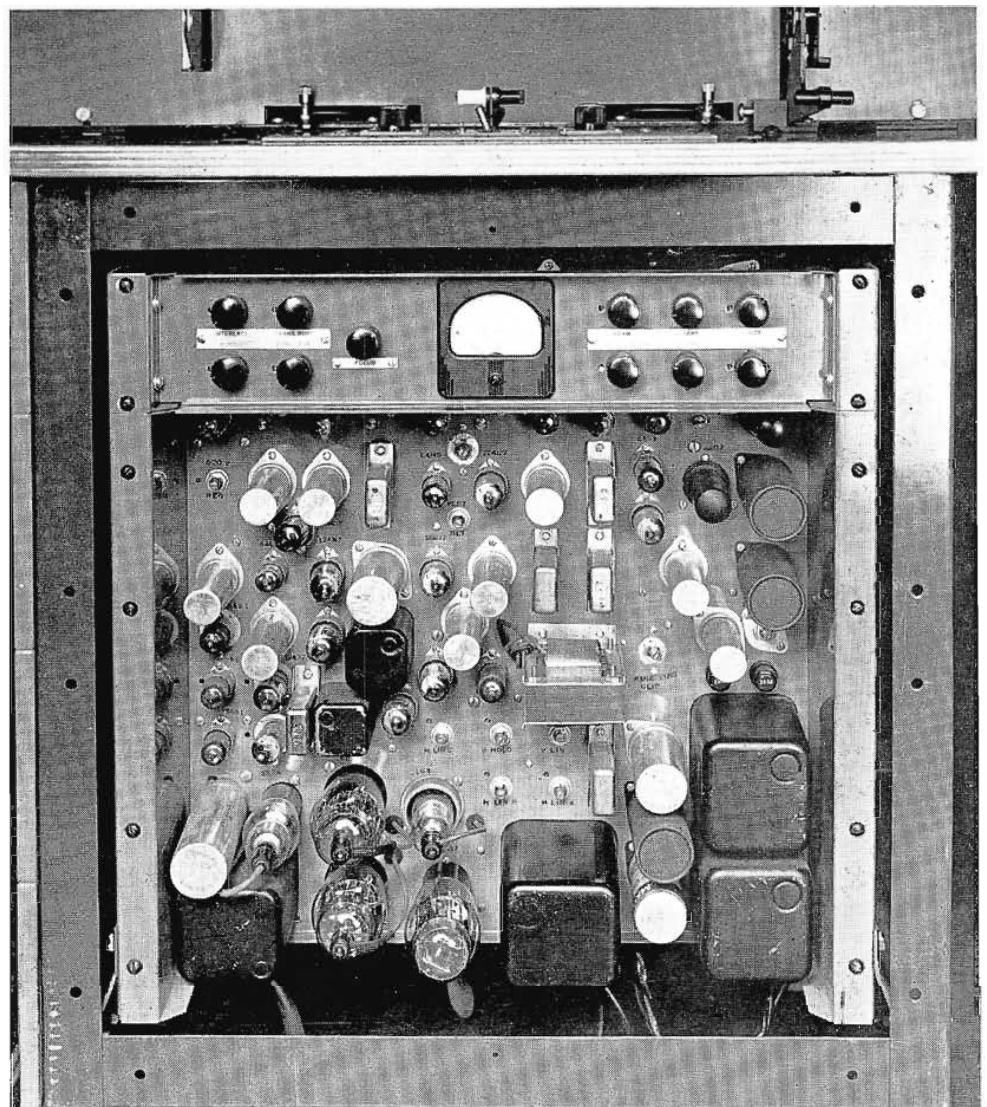
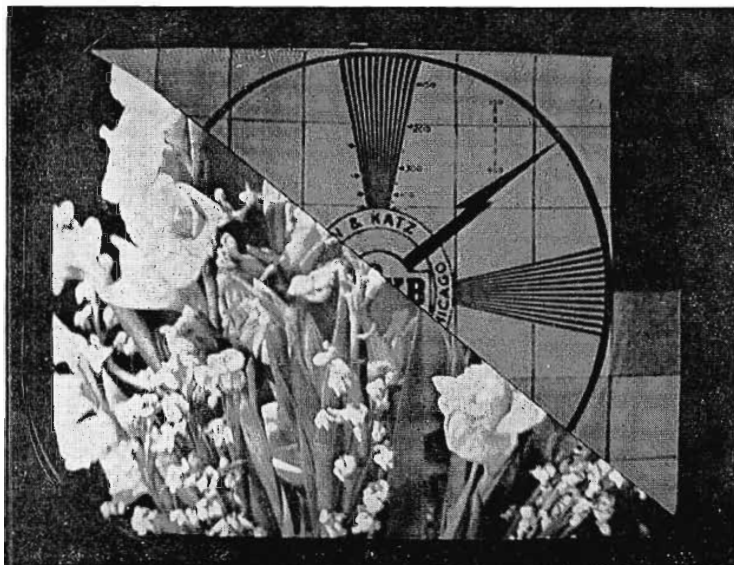

FIG. 6. As shown here, the cover panel is removable so that all tubes are accessible from the front.



# FLYING SPOT CAMERA TYPE TK-3A (Continued)



ANGLE WIPES, from lower left to top right, or vice versa, may be applied to any two picture signals from any source.

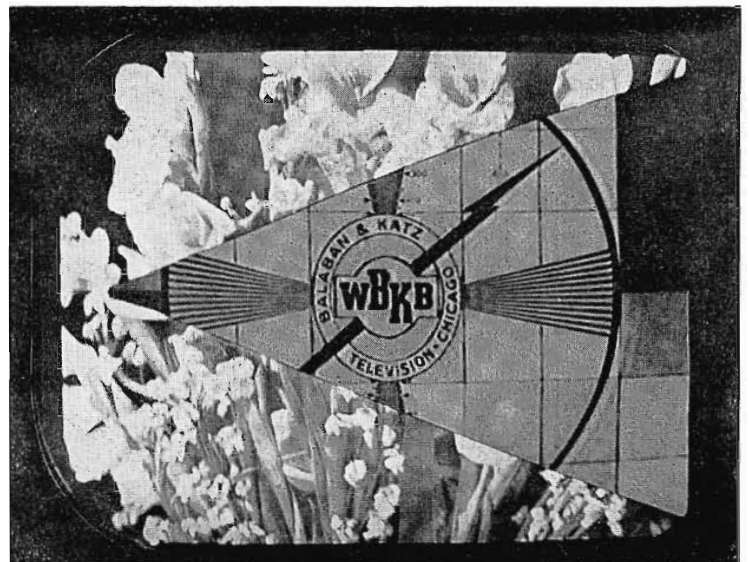

POINTED WIPES in which a wedged shaped area of one picture moves into—or out of—the area of another picture, are possible.

## THE NUMBER OF DRAMATIC

apply equally well when the transmitter site is at a distant point from the studio. Then, too, the small station with only a network program source would find the Flying Spot Camera very useful for inserting local announcements.

For actual program use, the turntable kinship mentioned before offers flexibility in application. For instance, with every dramatic production a list of characters is presented. This could easily be handled with the Flying Spot Camera while a studio camera, normally used for the purpose, would be freed for other uses. In the same way, short commercials, announcements, weather reports, or phone numbers may be setup, shown, and put away with a minimum of complications.

A typical location of the Flying Spot Camera in a studio may be seen in the background of Fig. 7. To the right is a video control console, and it will be seen that the Flying Spot Camera is therefore located beside the operator just as the record turntable is located beside the audio operator whose console is to the left.

FIG. 7 (left). View with front cover removed and with Video and Deflection chassis hinged down to make all wiring and small components accessible.

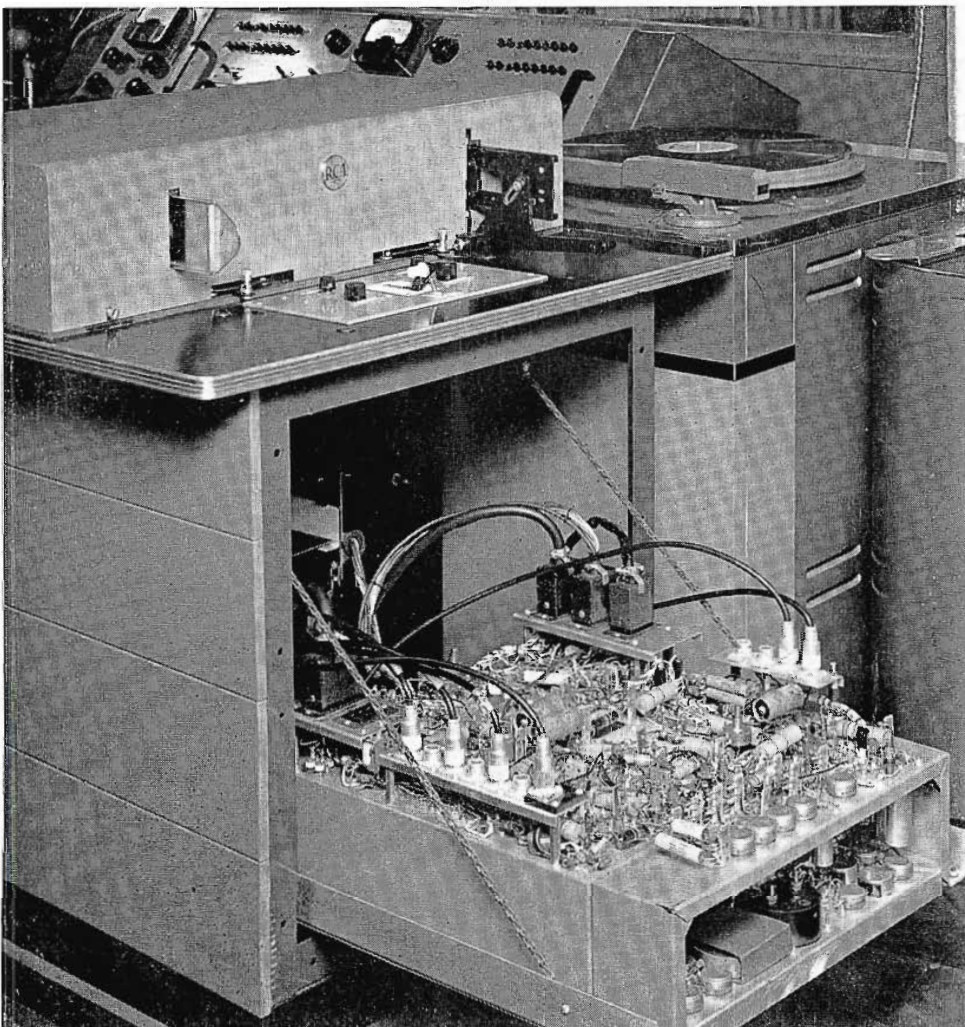

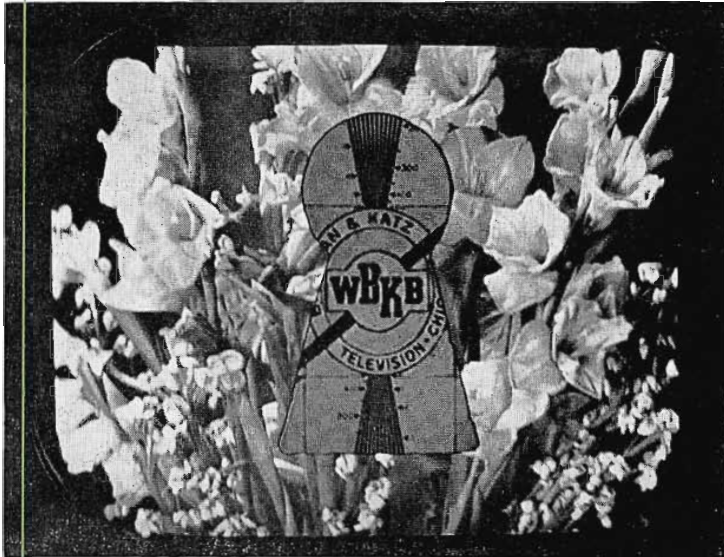

STRANGE SHAPED INSERTS, of any kind that the imagination can conceive, can be obtained by making a mask of the shape desired.

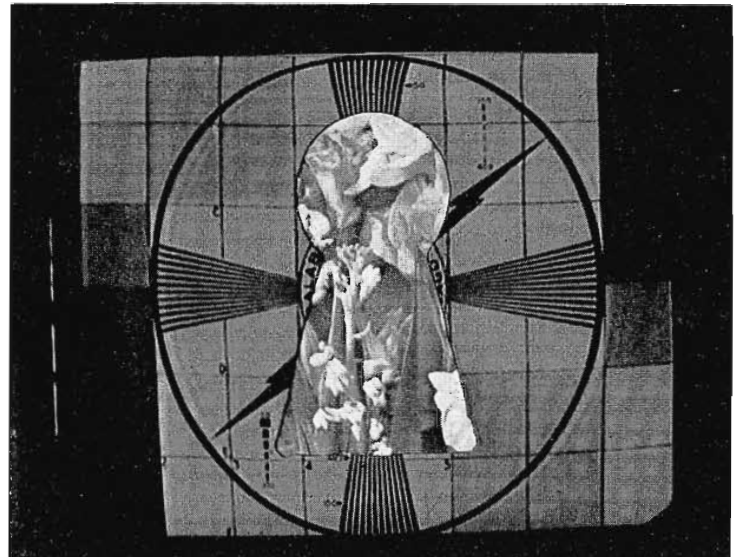

REVERSAL of the two pictures is accomplished by simple switching. Pictures from studio, remotes, film camera, etc., can be used.

## "VIDEO-EFFECTS" COMBINATIONS IS PRACTICALLY UNLIMITED

Not mentioned so far, but again illustrating the versatility of the Flying Spot Camera, is its use with the recently announced RCA Special Effects equipment. By means of a special mask assembly which may be fitted into one of the slide holder channels and actuated by an external lever, mask signals for the Special Effects keying may be generated. Infinite variety is possible, both for fixed cut-outs, or wipe effects when the sliding mask assembly is moved across the scanned area. The mask assembly is shown inserted into the right-hand slide holder position in several of the illustrations.

### General Specifications

Slide holders.....6 slides each  
 Slides.....2x2, double 35mm frame size  
 Output..Standard RMA level (1 v. peak to peak on 75 ohm line—1.4 v. with sync) 2 isolated output circuits  
 Limiting resolution (horizontal)..600 lines  
 Linearity .....2%  
 Auxiliary equipment...1 WP-33B Regulated Power Supply  
 Dimensions:  
 Table top.....30½ x 26 inches  
 Base .....25 x 25 inches  
 Height to table.....28 inches  
 Height over cover.....34½ inches  
 Stock Identification .....MI-26963



## Field Engineering Service to Broadcasters...AM, FM, TV

RCA Service Company engineers are experienced in all the latest techniques and are equipped with the most modern specialized measuring equipment. The RCA Service Company has been working hand in hand with the nation's broadcasters for over 25 years.

### OUR SERVICE TO BROADCASTERS...

- Installation supervision and measurements of transmitting, studio and accessory equipment . . . AM, FM or TV.
- Prompt help in emergencies. Technical advice, service, and assistance on special problems.
- Instruction and training of station operating personnel.
- Performance measurements and adjustments for station compliance with FCC regulations.
- Measurement and curves on FM and TV antennas and accessory equipment, including transmission lines, matching networks, diplexers.

*(For service outside the U. S. A., consult your Authorized RCA Distributor)*

**NOW—restore the original quality of your RCA microphones, transcription pick-ups and test and measuring equipment under the new Factory-Reconditioning Plan. For complete details, write: Return Apparatus Control, Building 8-2, Camden, N. J.**



**RCA Service Company, Inc.**

A Subsidiary of the Radio Corporation of America  
 CAMDEN, NEW JERSEY

# WKPT AND WKPT-FM

. . . 250 W AM, 10 KW FM

By THOMAS PHILLIPS Chief Engineer

WKPT, having the copyrighted slogan "The Nation's Model Station", is located in Kingsport, Tennessee. It was established in 1940 by a group of Kingsport businessmen headed by Mr. C. P. Edwards, Jr., President of the Kingsport Broadcasting Company, Inc., and Mr. Howard E. Long, Vice-President. It operates on 1400 KC with 250 watts and is an NBC affiliate.

In September of 1947 our studios, occupying the second floor of a two story building, were completely destroyed by fire. Only the outer brick walls were left. The fire started just before sign-on time, but the announcer went to the transmitter site and carried on from there, using an

RCA OP-6 and OP-7 remote amplifier and a couple of turntables . . . with the loss of only five minutes air time. Mr. P. G. Walters, Jr., RCA representative in Atlanta, came to our rescue and had RCA ship us immediately a 76-B2 Console, a couple of 70-D Turntables and a couple of mikes. In a few days these were set up in a temporary studio location downtown where we operated for 17 months before the studios were rebuilt.

This happened just at the time when we were planning our FM operations. Our WKPT-FM went on the air in February 1948 with an RCA BTF-3B 3 KW Transmitter. Three months later this was converted to the RCA BTF-10B 10 KW Transmitter. Our AM and FM studios are designed for complete separate programming of the two stations.

## General Studio Arrangement and Design

The second floor area to be occupied measures 130 by 48 feet with a ten-foot ceiling. Clear span joists were used leaving it free of vertical supports. Consultation, on the part of our Architect, Mr. Allen N. Dryden, a Director of the station, together with NBC engineers, resulted in raising the portion of the roof over Studio A six feet, in order to give a sixteen-foot ceiling for better acoustics and appearance.

We were faced with the problem of getting sufficient sound isolation between studios originating separate programs, since the building was not strong enough to support interior double masonry partitions. The layout was made so that no two studios were adjacent. Studio A is separated from studios B and C by the control rooms and the transcription library. Studios B and C are separated from each other by the corridor leading into the transcription library. The walls used were double stud and masonry partitions having no connections with each other, except for resting on the same concrete floor. One inch of plaster was applied and a rock wool blanket placed between the studs. This type construction is considered to give 56 db isolation. It has proved to be entirely satisfactory.

The building is located in a quiet area on a side street with very little heavy

vehicular traffic. The first floor is devoted to office space and presents no noise problem, and the concrete slab roof provides good isolation from outside noise.

The air-conditioning system was designed for low air velocities and the ducts were lined with sound absorbing material. The units were mounted on resilient supports and flexible couplings made to ducts, water pipes and wiring.

Studio A is 29 by 41 feet with a sixteen-foot ceiling. The sound treatment consists of Johns-Manville perforated Transite over rock wool sound absorbing blankets. One end wall consists of plaster polycylindrical diffusers and was given no absorbent treatment. There is a minimum of parallel wall surfaces. This factor, combined with the volume (17,000 cubic feet) and the sound absorbent treatment, gives excellent acoustical properties. When used as an audience studio it will seat 100 spectators comfortably.

Studios B and C are each 16 by 19 feet with ten-foot ceilings. These and the two control rooms are treated with Johns-Manville acoustic tile. Eight Riverbank 40-db sound isolating doors are used throughout the studios.

## Studio Control Rooms

Both control rooms look into studio A and either can control programs originating in this the largest studio. The Master Control room also looks into studio B and the Sub Control room into studio C. For the utmost in flexibility it was engineered to allow instant switching of the microphones, monitor speaker and cue lights of studio A from one control room to the other. All circuits are relay switched and operate simultaneously by a key located conveniently on the control panel in each control room. Red and green lights alongside the keys give visual indication of which control room has the studio circuits.

The control room floors are raised 24 inches above the studio floor level for better visibility into the studios. The Transcription Library is on the same level as the control rooms for convenience in going to and from the record files. These raised floors are of wood and each is separate, except for being supported on the concrete floor slab, to minimize sound transmission



FIG. 1 (at left). Entrance to studios and offices of WKPT and WKPT-FM.





FIG. 2. The Master Control room includes RCA Consolette, 70 series turntables, recorder attachments and equipment racks. Announcer Jack McKee is at the console controls.

FIG. 3. Lobby looking at Studio "A" entrance at left, and through Studio "A" into Sub Control room.



between rooms. The space beneath these rooms is used for wiring between studios and the control rooms, between control rooms, and between units within the control rooms. Entrance to this space is through a small door in the corridor. A platform on casters, like those used by automobile mechanics to get under cars, makes travel in this space quite easy.

Each of the control rooms has an RCA 76-B Consollette and two RCA 70-D Turntables. In the Master Control room are two racks containing line amplifiers, turntable pre-amplifiers for both control rooms, recording amplifier, monitor amplifier for the Manager's office and other associated equipment, such as line equalizers, repeat coils, orthacoustic filter, jacks, pads, etc.

The matter of program dispatching received most careful study. No control operators are used for this function which is being performed by the announcers. Since they must, of necessity, concentrate on announcing, program dispatching was made as simple as possible.

The switching requirements, to be met, lined up as follows. To feed WKPT from either control room and feed WKPT-FM from the other. To feed both from either control room simultaneously. To feed programs to WOPI in Bristol, Tennessee and to receive programs from them using either control room. Normally the line to WOPI is used for NBC programs. We receive NBC network programs from Knoxville; and, because of very noisy lines from Kingsport to Bristol, a repeater amplifier



FIG. 4 (at right). Studio "A"—looking into Sub Control room and Master Control room.



FIG. 5. Looking into Sub Control room and Studio "C" from Studio "A". Paul Overbay, Program Director, is at the controls. Announcer Jack McKee is in Studio "C". Program dispatching indicator lights are at right of console.

located in our control room, is used to step up the network level. It was also of advantage, when carrying network programs, to feed network direct and to use the console for auditioning; or, as speech input control during recording. These possible combinations made the use of the pre-set type dispatching system very desirable. With this arrangement all individual circuits could be set up well ahead of switching time and all thrown simultaneously with one master key. At the time of switching the announcer, who is practically always busy with station break and spots, need remember to throw only one switch and this always the same one. These program dispatching circuits can only be switched from the Master Control. In the Sub Control room indicator lights show the circuits in use and those set up for the next program switch.

Because from one to three outgoing program circuits were to be fed from the same Console, at times, individual line amplifiers were used to feed the telephone lines. Their inputs are fed from the dispatching panel. These amplifiers are RCA BA 3-C's; pads and repeat coils are used between them and the telephone lines.

Direct telephone communication between the transmitters and the control rooms is had by using the spare program lines and instruments with magneto ringers. The transmitter is automatically connected to the control room feeding it by

relays which are operated by the program switching keys on the dispatching panel. The telephone sets are connected through the normal contacts on the line jacks and are automatically disconnected when the patch cord is inserted, if the line is to be used for program, on failure of the regular line.

Provision was made to identify the AM and FM stations separately during program duplication. A non-locking telephone type key, in each control room and connected across the AM program line (after the line amplifier), is held down by the announcer during the letters "FM", as he makes the station identification.

Nearly all audio connections were of course terminated in jacks to permit operating flexibility, rapidity of isolating trouble and the substitution for defective units, and they, of course, facilitate routine testing. For instance in the event of trouble in one of the line amplifiers or dispatching panel they may be by-passed by patching from the line direct into the output of the Console.

Remote pickup lines are patched into the remote circuits of the console of the control room desired to handle the remote.

Each control room can monitor the other by using headphones. They may also signal the other by pushbutton operated lights.

A high quality monitor speaker is located in the manager's office, and wall mounted control panel permits pushbutton selection of programs from either control room or the network line; a gain control and on-off switch with pilot light are included. As mentioned before, the amplifier is mounted in one of the racks in the Master Control room. Conduit outlets and rack space for amplifiers have been provided for later installation of monitor speakers in the Sales and Program Director's offices.

#### FM Transmitter

WKPT-FM transmitter site is located on a mountain top having an elevation of 2300 feet above sea level and 1000 feet above Kingsport, two and a half miles distant. With a 142-foot overall tower, the effective height of the radiator is 961 feet above average terrain. An access road was already in existence although power and telephone service had to be constructed from a point two miles away.

Plans were made during 1946 to begin operation of the FM station early in 1947. But the loss of the studios from fire made it inadvisable to go on the air until the permanent studios could be re-built.

The FM transmitting equipment was ordered at the same time as the studio equipment and it was stored until we were

FIG. 6. Simplified schematic diagram showing the program circuit connections for WKPT and WKPT-FM.

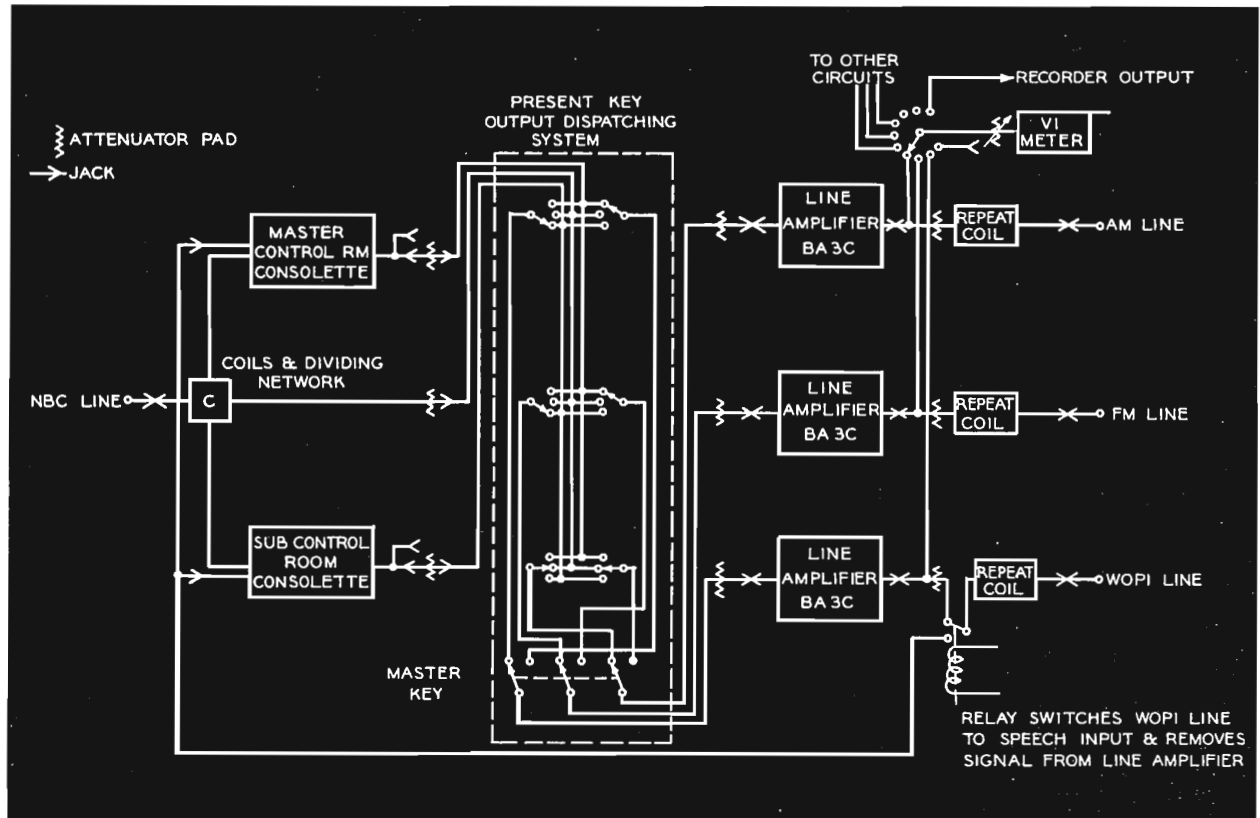

ready to install it. The racks were wired and various assemblies constructed by the engineering staff while the restoration of the studio building and the construction of the FM transmitter proceeded.

The contractor obliged by expediting the completion of the control rooms to the point where installation of the equipment could be carried on while the rest of the building was being finished. Work of construction of both buildings and installation of equipment went on simultaneously. They were finished so nearly at the same time that WKPT-FM went on the air with regular programs just ten days after the new studios were occupied.

Because of the danger of forest fires, principally, a fireproof transmitter building of stuccoed cinder block with concrete floor and roof was decided upon. It is approximately 30 by 30 feet in size.

#### RF Shielding and Grounding

Since intense r-f fields were to be in proximity to low level audio circuits it was thought best to take what reasonable precautions possible to shield one from the other. The iron wire reinforcing matting for the concrete roof and the metal lath for the ceiling were a natural for a shield between the antenna and the audio equipment in the building. Before the roof was poured, but with the matting in place, the several pieces of matting were brazed to-

gether, and to each roof bar joist. Later, when the metal ceiling lath was installed, it too was brazed together and to the bar joists, before plastering. A No. 8 copper wire was run down from this roof shield to each of the metal window frames and continued down and terminated to a six-inch copper strap buried to a depth of one foot and running completely around the building. Our equipment is tied in to this ground by means of a six-inch copper strap in the bottom of the floor trench used for inter unit wiring.

We went on the air in early February 1948, with an RCA BTF 3B, until delivery of the complete BTF 10B, 10 KW Transmitter could be made. The latter was installed during May and the conversion was made smoothly without loss of air time. The first night the 3 KW power supply was removed and the new 10 KW unit installed. The next night the 10 KW power amplifier was installed.

The audio equipment was installed in a single rack. A limiting amplifier is used to prevent over-modulation and to raise the average audio level; it is operated to compress about 3 db on peaks. The pre-emphasis filter is connected ahead of the limiter to prevent overmodulation on program material containing predominant highs. A BC-3C Audio Amplifier is used between the line equalizer and the pre-

emphasis filter to make up for the loss in these units. A BA-4B amplifier is used to drive the monitor speaker. Its input, of course, is connected to the output of the station monitor.

The transmitter is placed across one end of the room with the operator's desk in the center, facing the transmitter. To the right of the operator's desk is the audio rack. At the opposite end of the room from the transmitter is a built-in work bench, with ample storage space below and on each side for tools, spare tubes and parts and the usual accumulations. A storage closet is built in one corner behind the transmitter for the storage of cleaning implements.

Rain water caught on the roof runs through a sand and rock filter into a 7500 gallon cistern. A daily supply of about 90 gallons is caught on this roof area. An automatic electric pump lifts the water from the cistern into a pressure tank.

In warm weather the air is changed in the transmitter room about once a minute by a 26-inch exhaust fan. It is mounted in the wall next to the ceiling in the corner of the room nearest the power amplifier, the principle source of heat. There is no noticeable temperature rise in the room from the equipment with the fan in operation.

FIG. 7. The WKPT stuccoed tile transmitter building is located 2½ miles from Kingsport.



FIG. 8. The WKPT-FM transmitter building floor plan layout. All equipment is accommodated in a space approximately 30 feet by 30 feet.

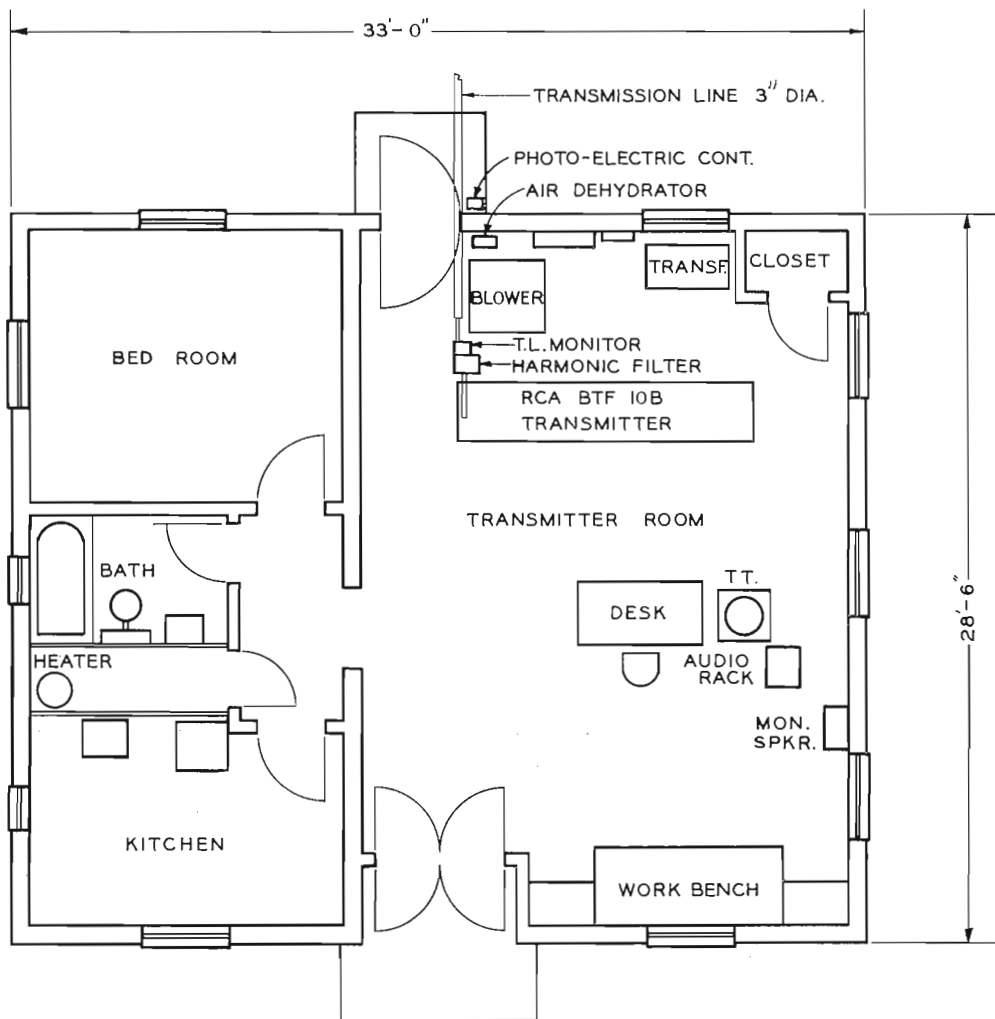

In the event of failure of both wire lines from the studio, a high grade communications type receiver is used to rebroadcast the programs from the AM transmitter. It also serves to check the modulation monitor by the Bessel zero method. Similarly the FM program can rebroadcast from the AM transmitter should its program circuits fail.

Sign-on and sign-off announcements are made from the transmitter by a recording.

**Antenna**

The antenna provides a power gain of 4.7. It is mounted on a 100-foot Blaw-Knox self supporting tower. The overall height above ground is 142 feet and is 50 feet from the building.

The 3⅝ inch transmission line is supported at 10 foot intervals by 2 inch pipe uprights imbedded in concrete. The average height of the transmission line above ground is 7 feet. A Communications Products automatic air dehydrator keeps the transmission line filled with 15 pounds of dry air.

A Crouse-Hinds photoelectric control switches the tower lights automatically. Our experience with lightning hits, we think, might prove helpful to others. The FM transmitter site is in a most exposed location; as are the utilities lines, running up the end of a mountain ridge. Soon after

going on the air, the first storm of the season hit. About a hundred dollars worth of damage resulted, mostly in the transmitter but also to other equipment connected to the electric service.

The power company felt that the trouble might be that our ground did not have as low a resistance as theirs; that the lightning surge hit our tower, went through our equipment and then through their lines to ground. So, we improved our ground by burying another six-inch copper strap 150 feet long. A quantity of charcoal was placed in the trenches and it was salted. The utility company measured the ground resistance and found it to be about three ohms. Since this was very low compared to the resistance of their iron stake ground at the transformer bank (250 ohms) they tied in to ours.

Very shortly another lightning storm did more damage. The power company was asked to install lightning arrestors on their lines at the building entrance. This they did and we believe that they were very helpful. However, we continued to get minor damage, on occasion, during storms. We asked them to install choke coils in the lines just after the arrestors and were told that the system had abandoned the use of chokes, as a result of its experience; but they would try them if we felt it would help. They were installed and consisted of 14 turns of insulated wire wound as a

single layer solenoid seven inches in diameter. A six-inch copper strap was run up the side of the building from the buried ground and served to ground the arrestors, with the idea of reducing the reactance to ground. Since they were installed over 18 months ago, we have not suffered any lightning damage whatsoever.

While we are on the subject of problems encountered another suggests itself wherein our experience may be helpful to others. A separate buried ground for the audio equipment was tried with a significant reduction in the line noise level.

We also found that the use of the line equalizer ahead of the repeat coil resulted in an intolerably high noise level, no doubt introducing an unbalance to ground. It was placed on the secondary side of the repeat coil.

Our attempts to equalize the program line were not productive of results to our satisfaction. With sufficient equalization to bring the highs to the proper level, an undesirable peak developed at 4,000 cycles. Separate runs were made on the line without equalization and on the equalizer with resistive terminations. Both showed smooth curves without unwanted characteristics. From this it was considered that the effect was caused by an impedance discontinuity (probably at the point where the telephone company's cable joined its open wire line

at the foot of the mountain) producing the peak when the equalizer mismatched the line at the low frequencies, as it normally does. So, a 9 db pad was tried between the secondary of the line repeat coil and the equalizer. It worked like a charm; the peak was completely removed. A 6 db pad is used between the output of the pad and the input transformer of the audio amplifier.

### Television

If and when television is upon us, we think we are very well situated with respect to building construction. Studio A is of a size and height, with its sixteen-foot ceiling, ideal for a small television operation. Already served by two control rooms, the transcription room also could be converted to a control room by merely adding a window. Also the Conference room would make a control room, or might be just the thing for storing props and equipment. The FM transmitter building would probably be the logical place for the television transmitter.

The staff numbers twenty people; headed by Mr. A. F. Martin, General Manager and including two salesmen; program director and four announcers, book-keeper, stenographer-receptionist, traffic manager, two continuity writers, chief engineer and five engineer-operators and a part time janitor.



FIG. 9. The RCA BTF-10B Transmitter with Chief Engineer Thomas Phillips, left and Engineer Washington Elitchco.

# TEST AND ALIGNMENT PROCEDURES FOR VIDEO AMPLIFIERS

By

**F. E. CONE and N. P. KELLAWAY**

TV Terminal Equipment Engineering

It is the purpose of this article to provide a general step-by-step guide or approach for the testing and alignment of video amplifiers<sup>1</sup> as well as specific alignment procedures for individual units of the RCA television terminal equipment.

Television station engineers and technicians concerned with the operation and maintenance of video amplifiers and other TV equipment should find this information particularly useful. Since many of the video testing procedures and techniques are relatively new and must be performed at relatively high frequencies, suitable test methods, adequate test equipment (which is available commercially) and sufficient care in making measurements are recommended.

The video signal is made up of many frequencies of varying amplitudes and characteristics. Faithful reproduction of this signal is obtained only when the amplifiers are relatively free from frequency, amplitude, and phase distortion over the required frequency band. Therefore, the testing procedures described in this article are confined to those characteristics which are most likely to affect the performance and quality of the video signal.

## Transmission Characteristics of Video Amplifiers

The frequency response characteristic of an amplifier indicates frequency distortion directly and is a means of judging

<sup>1</sup> J. H. Roe, "How to Adjust Frequency Response in Video Amplifier for TV". BROADCAST NEWS, No. 58, March-April, 1950, pp. 54 to 65, incl.

### CONTENTS

Transmission Characteristics of Video Amplifiers  
Specific Test Procedures:

- I. **TK-20A Film Camera Chain**
  - A. Film Camera, MI-26020 & MI-26020-A
  - B. Film Camera Control, MI-26075
  - C. Master Monitor, MI-26135-A
- II. **TK-1A Monoscope Camera, MI-26030 & MI-26030-A**
- III. **TK-30A & TK-10A Image Orthicon Camera Chains**
  - A. Field & Studio Cameras, MI-26000 & MI-26000-A; MI-26010 & MI-26010-A
  - B. Studio Camera Control, MI-26055
  - C. Field Camera Control, MI-26065
- IV. **Amplifiers & Switchers**
  - A. TA-1A Distribution Amplifier, MI-26155
  - B. TA-5B Stabilizing Amplifier, MI-26160
  - C. TA-5C Stabilizing Amplifier, MI-26160-B
  - D. TM-1A Program Monitor, MI-26140
  - E. TS-10A Studio Switching System, MI-26235
  - F. TS-30A Field Switching System, MI-26215
  - G. TA-10A Mixing Amplifier, MI-26281

phase distortion. This characteristic may be obtained by the well known point-to-point method. However, this is a time consuming task and is too cumbersome. A more convenient method uses a sweep frequency generator, a crystal detector, an oscilloscope with good low frequency response, and a square wave generator for 30 cycles and 7.5 kilocycles.

The sweep generator recommended is the RCA WA-21A. It consists of a fixed frequency oscillator and a sweep oscillator, frequency modulated at 60 cycles. The swing of the frequency modulated oscillator ranges from a few kilocycles on one side of the frequency of the fixed oscillator to 10 mc. on the other side. The beat frequency output over the usable range (100 kc. to 10 mc.) is of constant ampli-

tude within 1 db. This gives a well-defined zero frequency reference. The frequency marker pip which is available, covers the usable range of the sweep. Blanking is provided internally (60 cycle) to blank out the signal during retrace.

In conjunction with the sweep, a crystal detector is shown schematically in Fig. 2. It is a voltage doubler and rectifier which converts the frequency modulated signal to its envelope.

The efficiency of rectification is about 90%; hence in setting up a specific output level of 1.5 volts, the signal output of the detector should be approximately 1.35 volts. In constructing such a detector it is important that leads of components be kept as short as possible. Distributed capacity should be reduced to a minimum. The method of obtaining the frequency response of an amplifier is divided into two parts, the high frequency response (100 kc. and above) and the low frequency response.

## High Frequency Response

For this measurement, the sweep generator, the crystal detector, and the oscilloscope are used. The method consists of coupling the low impedance output of the sweep generator to the grid of an amplifier stage, the plate circuit of which contains the circuit to be checked or adjusted. The detector should be connected to some low impedance point of the following stage such as the unbypassed cathode.

The circuit of Fig. 3 indicates a typical video amplifier stage. Removing the cath-

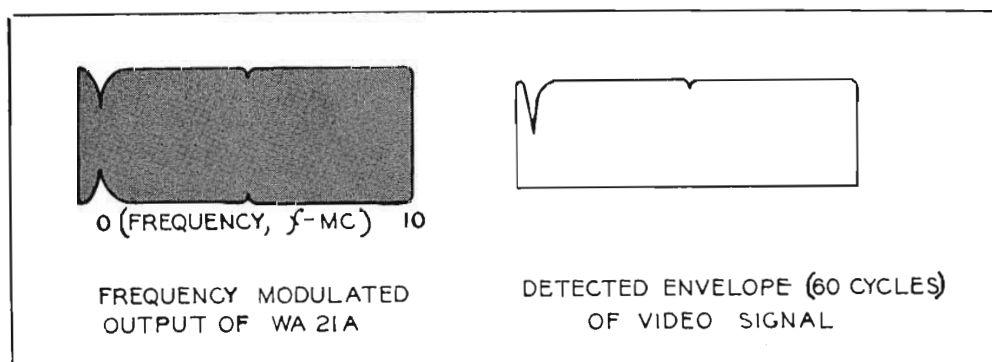
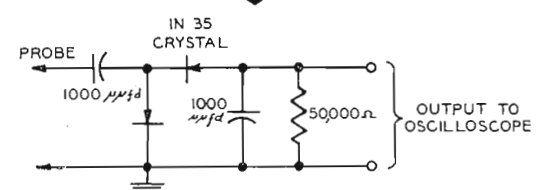

FIG. 1. Wave forms showing output characteristic of the WA-21A sweep generator.

FIG. 2. Schematic circuit of a peak-to-peak diode detector for use with sweep oscillator.



ode bypass capacitor makes this second stage a cathode follower. The cathode resistance is on the order of 100 ohms so that the effect of feed-through capacity will be negligible.

An alternative to this scheme is to leave the cathode bypass capacitor in place and connect a 100-ohm resistor across the peaking coils of the second stage to shunt both the series and shunt peaker. By attaching the detector across this resistor, this stage would then be a plate output stage.

Most of the amplifiers of the television terminal equipment are terminated with low impedance plate output stages or cathode followers. This affords a convenient point to attach the detector since the effect of the added capacity falls outside of the frequency band being considered. Hence, the detector is usually left there for the duration of the test.

The video sweep signal is then injected at the grids of the preceding stages, starting at the output end and progressing towards the amplifier input. Care should be exercised not to overload the amplifier, creating the illusion of a good response. The test signal should be the same as that handled by the amplifier during normal operation.

The specification given for various responses is representative of typical production equipment. Reasonable variations in response can be expected between units of the same type due to normal manufacturing tolerances.

In amplifiers where clamping, blanking, and sync signals are added, precautions are taken to maintain normal operating conditions. Clamping tubes add considerable capacity and affect circuit tuning. Such a tube is replaced with a tube of the same type that has its filament pins removed. A temporary grid leak resistor is added (470,000 ohms for 6AC7) to the opened grid.

Blanking is usually inserted by an amplifier, the plate of which shares a common plate load resistance with one of the video amplifiers. In addition to the circuit capacity it contributes, quiescent voltages of the video amplifier are dependent on the current drawn by the blanking amplifier. Thus, blanking cannot be removed by simply removing the blanking amplifier. Instead, the tube that drives the blanking amplifier (usually 1/2 6SN7) is replaced

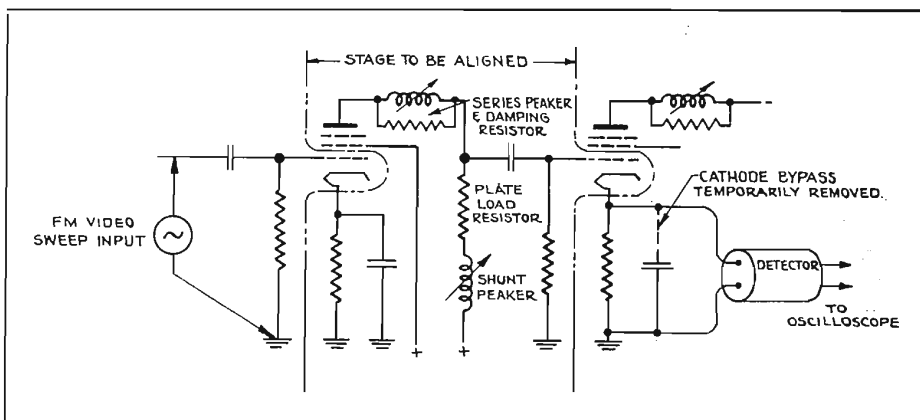

FIG. 3 (above). Typical Video Amplification Stage used in Television Terminal Equipment.

by a tube with its grid, plate, and cathode pins removed. These tubes should be plainly marked, possibly with red paint, to identify them. This will help prevent them from being left in the equipment.

It may occur that a high gain amplifier tends to regenerate and oscillate due to leads being attached to it. In such cases the alternative of disrupting the amplifier in parts will be sufficiently accurate to insure proper performance.

Beware of rapid variations in amplitude as shown in Fig. 4. Such variations of frequency response are accompanied by severe

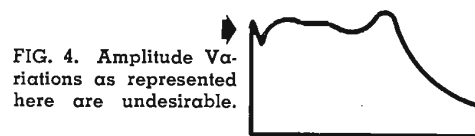
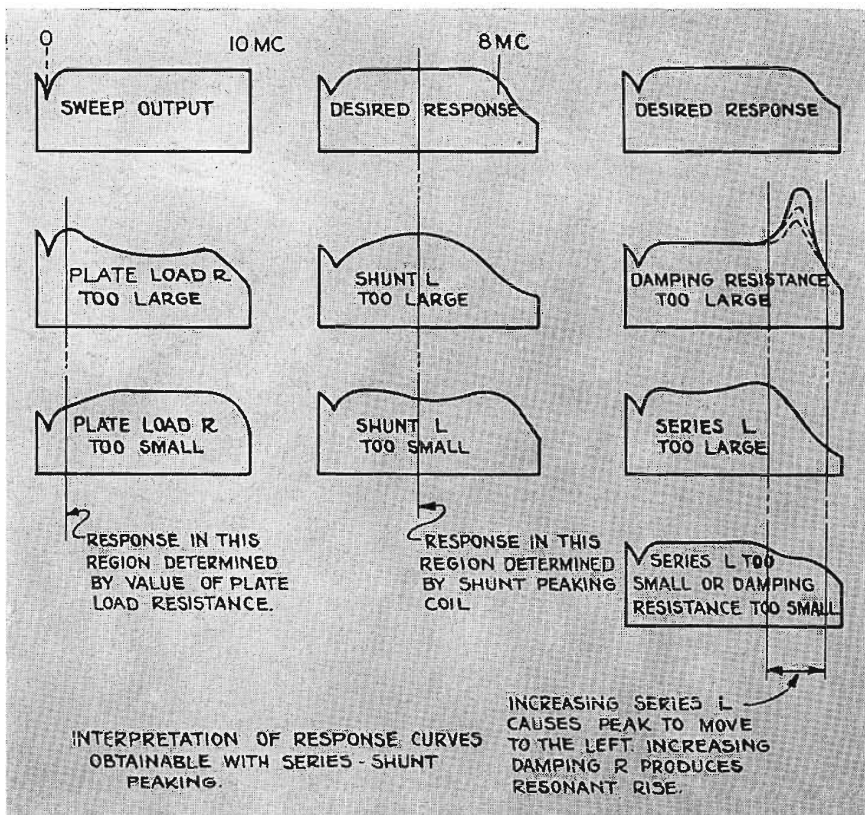

FIG. 4. Amplitude Variations as represented here are undesirable.

variations of the phase characteristic of the amplifier and may cause ringing or reflections in the video signal.

In carrying the frequency response of the typical series-shunt peaked stage out to 6 or 7 megacycles, the phase response should be good out to 5 or 6 megacycles. Assuming this phase response to be adequate, the difficulty of making phase measurements is eliminated.

FIG. 5 (below). The wave shapes below illustrate the interpretation of response curves obtainable with series-shunt peaking.



# ALIGNMENT PROCEDURES

## Low Frequency Response

The response of an amplifier at the low frequency end is usually determined by the time constant of the inner-stage coupling networks. The low frequency response requirements vary from unit to unit depending on their relationship with clamping. With clamping occurring at a horizontal rate, 30 cycle response is not necessary. However, the amplifier should pass a 7.5 kc. square wave with less than the specified maximum amount of tilt. This requires good phase response down to 7.5 kc. which implies good amplitude response down to 1/50 or less of this frequency when no special low frequency compensating circuits are employed. The 7.5 kc. square wave corresponds to a signal such as a bar extending the full width of the scene.

After clamping, the amplifier response should be such that the tilt should be less than the specified maximum for a 30 cycle square wave.

After alignment of any amplifier the final check should be the passage of a signal through it and close inspection of the signal on a monitor. The RMA Resolution Chart\* is a very useful signal source. The wide range of picture resolution gives rise to a wide range of frequency components and will be a good overall check.

\* See Bulletin #ED-2502-A prepared by TR4 Committee on Television Transmitters, Transmitter Section, RMA Engineering Department.

## I. RCA Film Camera Chain

### A. Film Camera—MI-26020, MI-26020-A

1. High Frequency Response
  - a. Disconnect output of iconoscope.
  - b. Connect detector across R32.
  - c. Align T-9, T-8, and T-7 associated with V-17, V-16, V-15, and V-14.

The response of these four stages should be essentially flat to 6.5 mc.

- d. Using V-14 as a cathode follower, connect detector to pin #2.
- e. Remove V-15.
- f. To eliminate high peaker circuit disconnect C-4 and change the connection of C-7 to other end of R-9.
- g. Align T-6.
- h. Ground grid of V-12 and inject sweep on cathode, pin #2.
- i. Align T-5.

The overall amplifier response, with peaking circuit eliminated, should be essentially flat to 6.5 mc.

- j. Return unit to normal operating condition.

### 2. Low Frequency Response

- a. Check to be made with high peaker circuit eliminated as outlined in "f" of High Frequency Response.
- b. Connect CRO across R32.
- c. Ground pin #1 and insert 7.5 kc. square wave at P-2 of V-12.

Note: It may be necessary to check amplifier in two steps as in High Frequency Response.

Tilt should be less than 10%.

- d. Return unit to normal operating condition and adjust high peaker with test pattern being fed in iconoscope.

### B. Film Camera Control—MI-26075

#### 1. High Frequency Response

- a. Replace V-9 with 6SN7, pins 4, 5, and 6 cut off (removes blanking).
- b. Replace V-2 with 6AL5, heater pins cut off (removes clamping).
- c. Add grid-leak (temporarily) of 500,000 ohms on V-3, pin 4 to ground.
- d. Turn BLACK LEVEL CONTROL (S-1) to OFF.
- e. Transient suppressor, R-24, should be at its maximum clockwise position.
- f. Terminate PICTURE OUTPUT and REMOTE MONITOR with 75-ohm terminations (not cables). Terminate MONITOR OUTPUT with 200 mmfd.
- g. Ground pin 4 to V-1.
- h. Connect detector across PICTURE OUTPUT and REMOTE MONITOR.
- i. Align T-3, T-2. Inject signal for T-1 alignment at Pin 5 of V-1.

The overall response should be essentially flat to 6 mc.

- j. Return unit to normal operating condition.

### 2. Low Frequency Response

- a. With conditions "a" to "g" inclusive of part 1 in effect, attach CRO across PICTURE OUTPUT.
- b. Insert 7.5 kc. square wave at pin 5 of V-1.

Tilt should be less than 10%.

- c. Insert 60 cycle square wave to pin 4 of V-3.

Tilt should not exceed 20%.

- d. Return unit to normal operating condition.

### C. Master Monitor—MI-26135-A

#### 1. High Frequency Response

##### a. Kinescope Amplifier

- (1) Remove kinescope socket (see below). Using an isolating capacitor in series with cathode side (terminal 6) connect the detector between grid (terminal 7) and cathode terminal of socket.

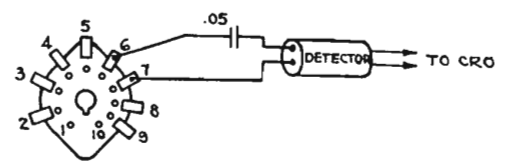

WIRING SIDE

FIG. 6. Socket connections used between CRO and Kinescope (1816P4).

- (2) Turn S-6 to DOWN position and set kinescope contrast (R-155) to maximum.
- (3) Align T-105 and T-104.

Response should be essentially flat to 7.5 mc.

##### b. CRO Amplifier

- (1) Set S-2 in VERTICAL position.
- (2) Apply 0.5 volt signal to PICTURE INPUT, J-2.
- (3) Align T-101, T-102, and T-103 by observing undetected output on Master Monitor CRO screen.

Response should be essentially flat to 4 mc. Tilt of the axis should not exceed 15% of the peak-to-peak signal.

#### 2. Low Frequency Response

##### a. Kinescope Amplifier

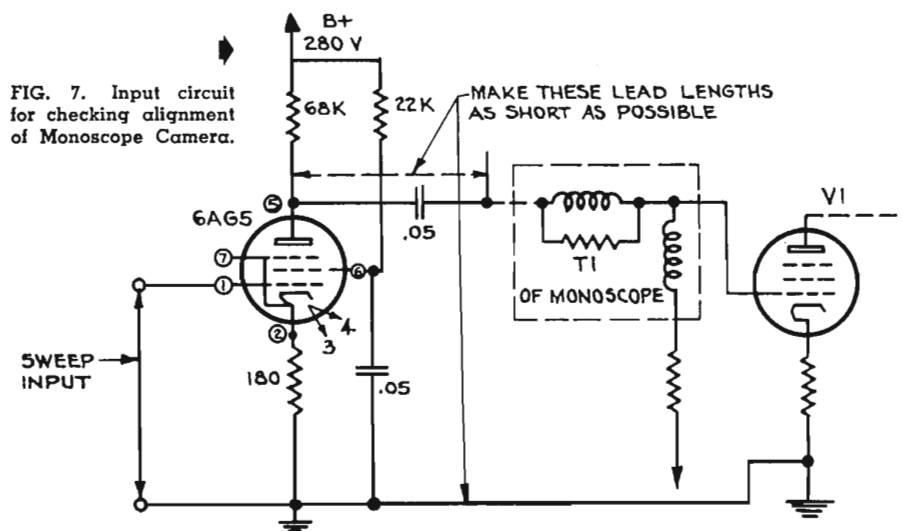

FIG. 7. Input circuit for checking alignment of Monoscope Camera.



# ALIGNMENT PROCEDURES

- (1) Switch S-6 DOWN.
- (2) Turn KINE CONTRAST maximum clockwise.
- (3) Apply 1.0 volt p-p 60 cycle square wave to PICTURE INPUT, J-2.

Signal at V11-3 as observed on a Cathode Ray Oscilloscope with good low frequency response should be 5% tilt or less.

## b. CRO Amplifier

- (1) Switch S-6 DOWN.
- (2) Switch S-2 in VERTICAL position.
- (3) Apply 1.0 volt p-p 60 cycle square wave to PICTURE INPUT, J-2.
- (4) Adjust CRO GAIN for 1.0" of deflection.

Tilt observed on monitor CRO shall be 5% or less.

## II. RCA Monoscope Camera—MI-26030 and MI-26030-A.

- A. Attach detector to PICTURE OUTPUT or MONITOR OUTPUT terminated with 75 ohms.
- B. Remove Blanking Signal.
- C. Set PICT.-EXT. switch, S-2, to EXT.
- D. Align T-7, T-6, T-5, and T-4. Response should be essentially flat to 8 mc.
- E. Insert 60 cycle square wave at pin 4 on V-6. Square wave should have less than 10% tilt and 10% overshoot.
- F. Remove V-2 and replace clamper tube V-9 with 6H6 with its filament pins removed.
- G. Add temporary grid leak (500 K) to pin 4 on V-6.
- H. Attach detector to pin 5 of V-6.
- I. Disconnect R-5 and add temporary grid leak to pin 4 of V-1.
- J. Align T-3 and T-2. Response should be essentially flat to 8 mc.
- K. Insert 7.5 kc. square wave. Square wave should have less than 10% tilt.
- L. To align T-1, reconnect R-5 to grid (pin 4) of V-1. Remove temporary grid leak at this point.
- M. The circuit shown in Fig. 7 is one way to simulate the output capacity of the Monoscope tube and provide the means of injecting the video sweep. The tube designated here might well be changed to any pentode such as 6AK5, 6AC7, etc. Because of the size of the plate load resistor, input circuit of V-1 becomes principal signal load.
- N. With circuit connected as above, inject sweep at pin 1 of 6AG5. Response of input circuit should be essentially flat to 8 mc.
- O. Return unit to normal operating condition.

## III. RCA Image Orthicon Camera Chains (for Master Monitor see I. Film Camera Chain)

- A. Field and Studio Cameras—Studio, MI-26000 and MI-26000-A; Field, MI-26010 and MI-26010-A.

### 1. High Frequency Response

- a. Disconnect input capacitor, C-13, to PICTURE AMPLIFIER, V-2, and remove image orthicon socket.
- b. Close S-6 by compressing turret handle and fasten in this position. This opens coaxial line and inserts 51-ohm resistor.
- c. Attach detector to low side of R-23, 150-ohm resistor directly below V-7.
- d. Maintaining amplifier output at approximately ½ volt peak-to-peak, align T-8 and T-7.

Response should be essentially flat to 8 mc.

- e. Set gain control to maximum and high peaker to its mid-capacity position.
- f. Using the network of Fig. 8, feed a 100 Kc. square wave to pin #1 of V-2.

tor across MONITOR OUTPUT to simulate monitor cable capacity.

- (5) Set Cable Switch to 100 feet and set TRANSIENT SUPPRESSOR, R-22, to maximum clockwise position.
- (6) To align T-3, connect detector at PICTURE OUTPUT and inject signal at pin #4 of V-13. Output signal level should be 2.0 volts.
- (7) Align T-2 and T-1, maintaining 1.5 volts output at PICTURE OUTPUT. Input to first picture amplifier should be made at pin #24 of camera cable receptacle.

Overall response should be essentially flat to 6.5 mc. Switching the CABLE LENGTH switch to 500 feet, the response characteristic

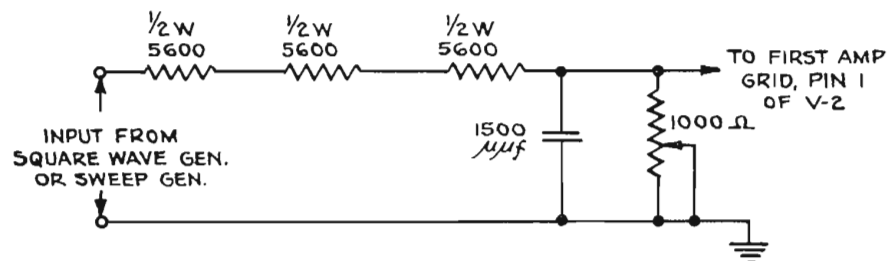

FIG. 8. Input circuit for checking response of Image Orthicon Camera.

Set the 1000-ohm pot at the input so that the square wave is reproduced with *no tilt*. Do not change the setting of potentiometer. Remove square wave generator and insert video sweep, through network. Align T-5 and T-6 using signal inserted at this point.

Overall amplifier frequency response should be essentially flat to 7 mc. Gain of amplifier connected as above shall be equal to or greater than 1/10 the signal fed into the input network.

- g. Return unit to normal operating conditions.

### 2. Low Frequency Response (Applicable only to units modified according to Technical Bulletin #JB65.)

- a. Repeat step "f" of High Frequency Response using 7.5 kc. square wave. Tilt shall be less than 10%.

### B. Studio Camera Control—MI-26055

1. If control is to be checked by itself, the following procedure is recommended:

- a. High Frequency Response
  - (1) No driving or blanking pulses to be applied.
  - (2) Replace V-14 with a 6AL5, with filament pins removed.
  - (3) Add temporary grid leaks, 470,000 ohms, pin 4 of V-16 and V-13 to ground.
  - (4) Connect 75-ohm terminations on PICTURE OUTPUT, J-9, and REMOTE MONITOR OUTPUT, J-6. Add 200 mmfd. capaci-

should remain unchanged at the low frequency end but rise uniformly to be approximately 1.5 times the low frequency response at 6.5 mc. Similarly, switch to 1000 ft. The response characteristic should remain unchanged at the low frequency end but rise to be approximately 2.5 times the low frequency response at 6.5 mc.

- (8) The output at REMOTE MONITOR should show the same frequency response as PICTURE OUTPUT.

- (9) Return unit to normal operating conditions.

### b. Low Frequency Response

- (1) With conditions 1 to 5 inclusive of part (a) in effect, attach CRO across PICTURE OUTPUT.
- (2) Insert 60 cycle square wave at pin 4 of V-13. The square wave shall have less than 10% tilt.
- (3) Return unit to normal operating condition.

2. If the STUDIO CAMERA CONTROL is to be checked with a monitor, etc., the following procedure is recommended:

- a. High Frequency Response
  - (1) Remove blanking pulses by replacing V-12 with 6SN7 with pins 1, 2, and 3 removed.
  - (2) Replace V-14 with a 6AL5 with filament pins removed.
  - (3) Add temporary grid leak, 470,000 ohms, to pin 4 of V-13.
  - (4) Turn GAIN potentiometer to maximum.

# ALIGNMENT PROCEDURES

- (5) Connect 75-ohm terminations of PICTURE OUTPUT, J-9, and REMOTE MONITOR, J-6.

- (6)
- (7) } These steps are same as those
- (8) } outlined in part 1-a.
- (9) }

- (10) Return unit to normal operating condition.

## b. Low Frequency Response

- (1) With conditions 1 to 5 inclusive of part (a) in effect, attach CRO PICTURE OUTPUT.

Procedure and response same as those outlined in part 1-b.

## C. Field Camera Control—MI-26065

### 1. Picture Amplifier

#### a. High Frequency Response

- (1) Replace V-12 with 6SN7 with pins 1, 2 and 3 removed.
- (2) Replace V-4 with 6H6 with pins 2 and 7 removed.
- (3) Insert 500,000 ohms resistor from pin #4 of V-3 to ground.
- (4) Turn GAIN to maximum and terminate PICTURE OUTPUT.
- (5) Attach detector to PICTURE OUTPUT and align T-8, T-3, T-2, and T-1, injecting sweep at grids of picture amplifiers V-7, V-3, V-2, and V-1 respectively, maintaining 2 volt signal at output.

The response of V-7 stage falls off gradually starting at approximately 5 mc. The overall response is made essentially flat to 6.5 mc. by over compensation of the preceding stages.

#### b. Low Frequency Response

- (1) With conditions 1 to 4 inclusive of part a. in effect, attach CRO across PICTURE OUTPUT.
- (2) Insert 60 cycle square wave at pin 4 of V-3.

The square wave shall have less than 10% tilt.

- (3) Insert 7.5 kc. square wave at pin 4 of V-1.

The overall square wave response shall have less than 10% tilt.

### 2. Kinescope Amplifier

- a. Remove kinescope socket (see below). Using an isolating capacitor in series with the cathode side (terminal 6), connect detector between grid (terminal 5) and cathode terminals of socket.
- b. Align T-5.

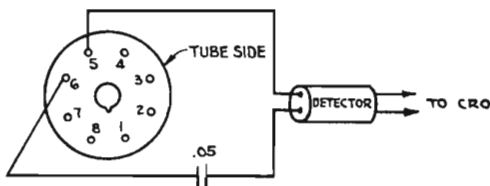

FIG. 9. Socket connections used between Field Camera Control Kinescope (7CP4) and "CRO".

The response from pin #4 of V-1 to pin #5 of V-30 should be flat to 5.5 mc. and then fall off gradually.

- c. Varying the CONTRAST from minimum to maximum should increase the amplitude approximately 50% without affecting frequency response.
- d. Square wave response shall be same as outlined in part 1-b.

### 3. CRO Amplifier

This is best observed directly on the camera control CRO as a video envelope.

- a. Align T-6 with V-11 removed and T-7 with V-10 removed. The response with V-10 and V-11 in place should be essentially flat to 5.5 mc.
- b. Square wave response should be same as that outlined in part 1-b.
- c. Return unit to normal operating conditions.

## D. Field and Studio View Finders—MI-26015, MI-26005

1. Remove kinescope socket. Using an isolating capacitor in series with cathode side (terminal 7) connect detector between grid (terminal 5) and cathode. (See Fig. 10.)

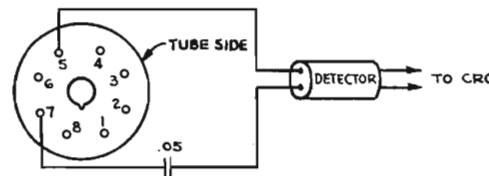

FIG. 10. Socket connections used between View Finder Kinescope (5FP4) and "CRO".

2. Turn CONTRAST to maximum.
3. Align T-5 and T-4.

Response of amplifier should be essentially flat to 5.5 mc. Contrast should cover range of approximately 6 to 1. Overall gain should be approximately 40.

4. Return unit to normal operating condition.

## IV. RCA Amplifiers and Switchers

### A. TA-1A Distribution Amplifier—MI-26155

#### 1. High Frequency Response

- a. Set GAIN to approximate mid-position.
- b. Terminate output in 75 ohms.
- c. Apply a 2.0 volt peak-to-peak video sweep to the input jack.
- d. Align T-1.

Response should be essentially flat to 8.5 mc.

Repeat the above test for each of the five sections individually.

Note: Where input and output is greater than 2.0 volts peak-to-peak, but no greater than 4.0 volts peak-to-peak (such as from a synchronizing generator), remove the 5600-ohm resistor in the plate circuit of input tube. This change limits high frequency response. Amplifier is then used strictly for pulse distribution.

### 2. Low Frequency Response

- a. Terminate output jack with 75 ohms.
- b. Feed 2.0 volts peak-to-peak 60 cycle square wave to input.
- c. Adjust GAIN for unity gain (2.0 volts peak-to-peak out).
- d. Adjust L.F. PHASE for minimum tilt and best flat topped square wave.

### B. TA-5B Stabilizing Amplifier—MI-26160

#### 1. High Frequency Response

- a. Replace diodes V-10, V-14, and V-15 with dummy tubes (filaments open).
- b. Return grids of V-7 and V-9 to ground through 0.5 megohm resistors.
- c. Cut off V-5. (Place grid at -22 volts through approximately 470,000 ohms.)
- d. Terminate PICTURE OUTPUT and MONITOR OUTPUT in 75 ohms.
- e. Apply video sweep to pin 4 of V-7. Align T-5 for response as in Fig. 11.



FIG. 11. Frequency Response of Stage including "T-5" of TA-5B Stabilizing Amplifier.

- f. Align T-4 to compensate for T-5 so that response is flat to 7.5 mc.
- g. Align T-3, T-2, and T-1.

Response should be essentially flat to 8 mc.

#### 2. Low Frequency Response

- a. Feed 60 cycle square wave to pin 4 of V-7.
- b. Signal at terminated PICTURE OUTPUT and MONITOR OUTPUT should have less than 10% tilt.
- c. Return unit to normal operating condition.

### C. TA-5C Stabilizing Amplifier—MI-26160-B

#### 1. High Frequency Response

- a. Terminate PICTURE OUTPUT and MONITOR OUTPUT in 75 ohms. (Do not terminate Sync Output.)
- b. Place S-1, LOW-HIGH switch, in LOW position.
- c. Set R-93, MONITOR GAIN, and R-49, SYNC LEVEL, at mid-position.
- d. Connect a 470,000 ohm resistor between pin 4 of V-4 and ground. It may be necessary to return the resistor to a negative bias voltage.
- e. Insert a dummy 6AC7 and 6H6 (filaments open) for V-9 and V-14 respectively.
- f. Connect sweep detector to PICTURE OUTPUT.
- g. Apply video sweep to V6-4. Align L-4A and 4B for response as in Fig. 12.
- h. Align L-3A and 3B for response as in Fig. 13.
- j. Adjust input signal to 0.25 volt peak-to-peak. Align L-2A and 2B to obtain response as in Fig. 14.

# ALIGNMENT PROCEDURES

- k. Inject signal at PICTURE INPUT jack and adjust PICTURE GAIN for 0.1 volt peak-to-peak at V1-4 (if it is necessary to use last 25% of maximum counter-clockwise rotation on PICTURE GAIN, switch S-1, LOW-HIGH switch, to HIGH and readjust signal to 0.1 volt peak-to-peak at pin 4 of V-1. Align L-1 to give Fig. 15.

The overall frequency response should be essentially flat to 7 mc.

## 2. Low Frequency Response

- a. Apply a 60 cycle square wave pin 4 of V-5 to obtain 1.5 volts at PICTURE OUTPUT.

The tilt should be less than 10%.

- b. Return unit to normal operating condition.

## D. TM-1A Program Monitor—MI-26140

### 1. High Frequency Response

- a. Remove V-17 kinescope socket.  
b. Connect detector between terminal 7 of socket and terminal 6, inserting a .05 mfd. blocking capacitor between the latter.  
c. Turn CONTRAST maximum clockwise.  
d. Align Z-2 and Z-1.

Response should be essentially flat to 7 Mc.

### 2. Low Frequency Response

Inject 60 cycle square wave, 1.0 volt peak-to-peak, to PICTURE INPUT, J-1.

Tilt at kinescope socket should be 10% or less.

Return unit to normal operating condition.

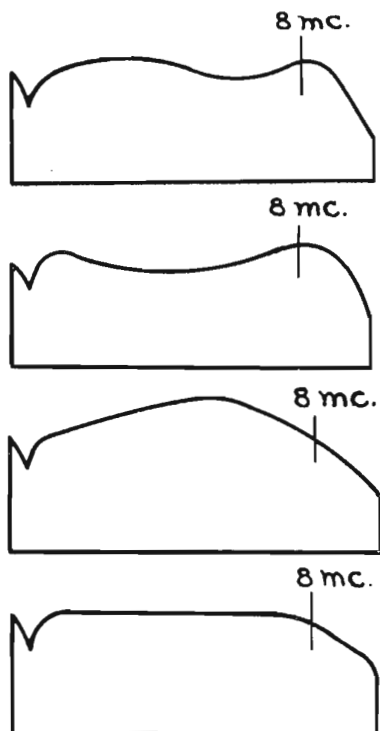

FIGS. 12, 13, 14 and 15 (above). Intermediate and overall Frequency Response Curves of TA-5C Stabilizing Amplifier.

## E. TS-10A Studio Switching System—MI-26235

### 1. Monitor Amplifier

- a. Apply video sweep of 1.0 volt peak-to-peak to J-7, MONITOR PICTURE INPUT. Set MONITOR SWITCH in 1st position.  
b. Connect detector to MONITOR jack, J-9, terminated in 75 ohms.  
c. Adjust MONITOR GAIN for 1.0 volt peak-to-peak sweep out at MONITOR jack.  
d. Align T-1.

Response should be essentially flat to 8 mc.

- e. Connecting sweep to Aux. #5 or Aux. #6 with AUX. GAIN controls at maximum should give same response as above. (Change monitor switch to positions #2 and #3 respectively.)

### 2. Channel "A" and "B"

#### a. High Frequency Response.

- (1) Terminate PICTURE OUTPUT in 75 ohms.  
(2) Apply video sweep to CAMERA CONTROL #1 jack, J-1.  
(3) Push up A and B selector buttons for this input.  
(4) Connect detector to PICTURE OUTPUT.  
(5) Operate PICTURE FADING controls together from "A" to "B" channel maximum gain position.

The response at either maximum gain position shall be essentially flat to 10 mc. At mid-gain position the response should be down approximately 10% of mid-band response.

- (6) Repeat above for J-2 to J-6 inputs.

Note: When testing at jacks J-5 and J-6, switching MONITOR SELECTOR switch to positions #2 and #3 respectively will tend to decrease frequency response, but only very slightly.

## F. TS-30A Field Switching System—MI-26215

### 1. Picture Amplifier

- a. Connect 470,000 ohm resistor from pin #4 of V-8 to ground.  
b. Replace V-6 with 6H6 with filament pins clipped.  
c. Remove sync input, and switch SYNC to EXT.  
d. Set PICTURE GAIN at mid-position.  
e. Attach detector at PICTURE OUTPUT.  
f. Align T-26 and T-25 respectively, maintaining 1.5 volts peak-to-peak output.

Response should be essentially flat to 8 mc. Gain should be unity.

- g. Check 6 input positions.

### 2. Monitor Amplifier

- a. Terminate MASTER MONITOR, J-30, (output jack) with 75 ohms.  
b. Switch monitor switch to SPARE INPUT to MONITOR and insert sweep signal, 1.5 volts peak-to-peak.  
c. Set MASTER MONITOR GAIN to mid-position.  
d. Align T-28.

Response should be essentially flat to 8 mc.

### 3. Sync Amplifier

- a. Insert video sweep at SYNC INPUT, J-32, and turn SYNC GAIN, R-71, to maximum position. The gain shall be at least 0.35.  
b. Turn SYNC switch, S-26, to EXT.  
c. Attach detector to PICTURE OUTPUT, J-31.  
d. Align T-29.

Response should be essentially flat to 3 mc.

- e. Return unit to normal operating condition.

## G. TA-10A Mixing Amplifier—MI-26281

### 1. High Frequency Response

- a. Attach detector to output, J-9, terminated in 75 ohms.  
b. Insert 2.0 volts peak-to-peak sweep to CHANNEL #1.  
c. With FADER CONTROL to maximum for CHANNEL #1 and minimum for CHANNEL #2, align Z-1.

Response should be essentially flat to 7 Mc.

- d. Fade to CHANNEL #2, inserting sweep at CHANNEL #2 input.  
e. Readjust Z-1 if necessary to compromise response for both channels.

### 2. Low Frequency Response

- a. Adjust fader to maximum position for CHANNEL #1, minimum for CHANNEL #2.  
b. Set bias at maximum clockwise position.  
6. Insert 60 cycle square wave, 2 volts peak-to-peak, at input, J-1.  
d. Adjust L.F. PHASE, R-10, for square wave response.

Tilt should be less than 10%.

- e. Insert signal at INPUT #2 and fade from CHANNEL #1 to CHANNEL #2.

Without adjustment, tilt should be same as for CHANNEL #1.

FIG. 15. Square Wave Response of TA-5C Stabilizing Amplifier.

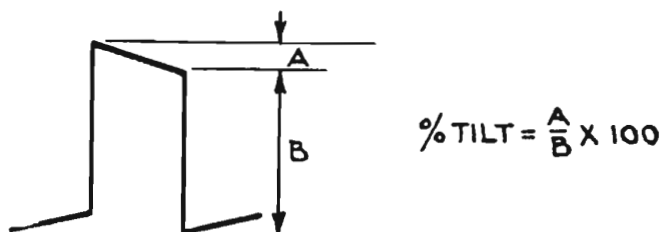

# THE REQUIREMENTS OF TELEVISION STATION DESIGN

By DR. WALTER J. DUSCHINSKY\*

## PART I

### The General Problem Of TV Station Design

Producing and maintaining television programs calls for perhaps the most involved and complicated operation undertaken by man. Behind the actor lies an army of production, technical and administrative personnel, whose specialized contributions to the whole must be efficiently integrated within the most efficient plant facilities that can be devised.

Television stations in the past few years have grown like Topsy. Make-shift additions have been made to make-shift beginnings, and present operations are suffering from inefficient, uneconomical plant facilities.

The time has now come to rectify past mistakes and develop the most functional quarters that can be evolved for such a highly complex enterprise, to be prepared for the competitive future of this now fully established business.

The development of television station facilities, however, can never be achieved

by existing methods and current practices, and it is not enough to entrust the design of television stations to the joint capacities of architects and engineers alone.

In reviewing the drawings of existing and proposed television buildings, including even those of latest design, it is evident that the basic essentials for successful production and operation are lacking. The reason for these shortcomings is largely due to the fact that, in the general specification for new television buildings, most of the requirements have been specified by either the architect or the engineer, who in turn have received their information from the operational and maintenance departments. As the growth of television has been enormous both in networks and individual stations; operation, production and administrative personnel have had no time to create their own planning apparatus. Therefore, all information supplied to the architect is departmental and often personal in character. It is apparent that if engineering is strongly

represented, technical facilities are favored, and when production has the upper hand, their own particular interests are overstressed in any new plant design.

In present and in some proposed television plant designs, clients have been lulled to sleep by the very properly executed architectural and engineering sketches of their consultants. But while the execution of these plans and drawings may show exactitude and general architectural and engineering knowledge, this does not guarantee an economical and efficient plant design. The basic facts, on which such plans are built, are, in nearly all cases, incorrect or at least misunderstood. This cannot help but lead to unnecessarily high capital expenditure and constant high operational costs.

The complexities involved in designing a television station require, as never before, the top-level coordination that only

\* Nowland & Schladermundt, Industrial Designers, New York, Philadelphia.

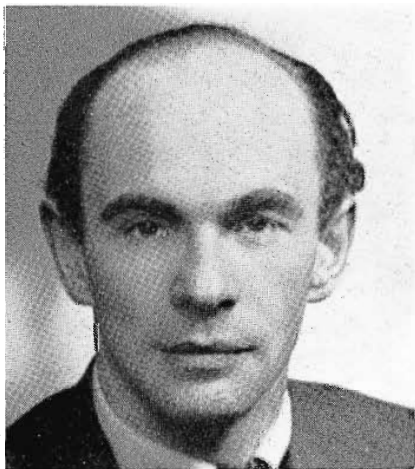

DR. WALTER DUSCHINSKY

## ABOUT THE AUTHOR

DR. WALTER DUSCHINSKY studied in the Universities of Prague, Brno, and attended Architectural and Aeronautical courses in the Bauhaus Dessau and the Polytechnic, Zurich. His field is the planning of large scale industrial and technological projects. His work in Europe included planning and organization of complex factory plants, air transportation and broadcasting facilities. In the United States since 1947 he worked on the Telecommunications facilities for the new United Nations Headquarters in Manhattan. At present he is a consultant on television plant design for individual stations.

In the four-part article which he is specially writing for BROADCAST NEWS publication Dr. Duschinsky plans to discuss: first, the general problems of TV station design; second, the planners' approach to these problems; third, the involvement of a general design; and, fourth, the application of the general design to a particular station problem. The first installment of this series is presented herewith. The second, third and fourth parts will appear in succeeding issues of BROADCAST NEWS.

Final evolution of the circular horizontal studio design as visualized by Dr. Duschinsky. Such a structure might be utilized in a large network installation or in a "Television City" serving a number of stations or networks.

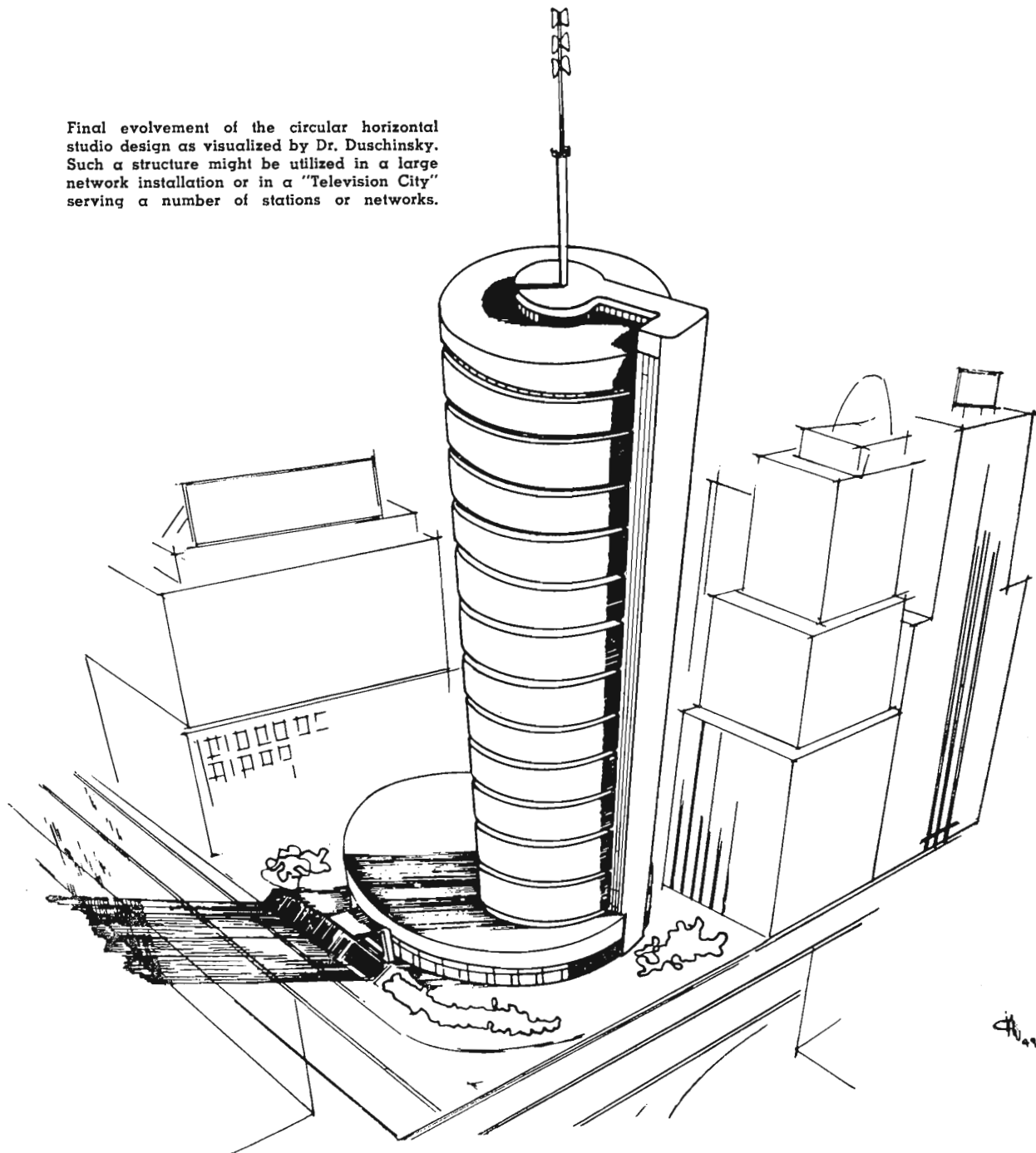

a planner can give to the development of specifications. Such a man, by his approach in collecting facts, and his experience with empirical results, can unite all aspects of the problem. Through an analysis of the requirements of any specific undertaking he can originate overall specifications and guide their actual development. The planner does not need to go into the detail required of the specialist—the architect and engineer—but must understand their problems before he can at top level formulate the overall picture of the problem that the specialists individually cannot achieve.

It goes without saying that very few of the architectural and construction organizations have the time and money to keep a staff of scientists, architects, engineers, producers, technologists and artists permanently employed. For this reason, it is apparent that this task of developing the design specifications of television station plant should be left to trained persons specializing in the top level planning of television installations, and fulfilling the requirements of the aforementioned group of specialists through a basic analytical study of each station's needs.

The top level planner will have to assemble the necessary data to conduct an effective analytical study, and must be fully conversant, not only with television statistics, but also with translating them into human factors of television production.

To produce a functional and efficient television plant layout, all deciding facts must be collected and used in an analytical study. Such facts are the available statistics on television plants, the information supplied by the management and the stations, and specific surveys made by the planner himself. Basic facts, such as a sta-

# THE ARRANGEMENT

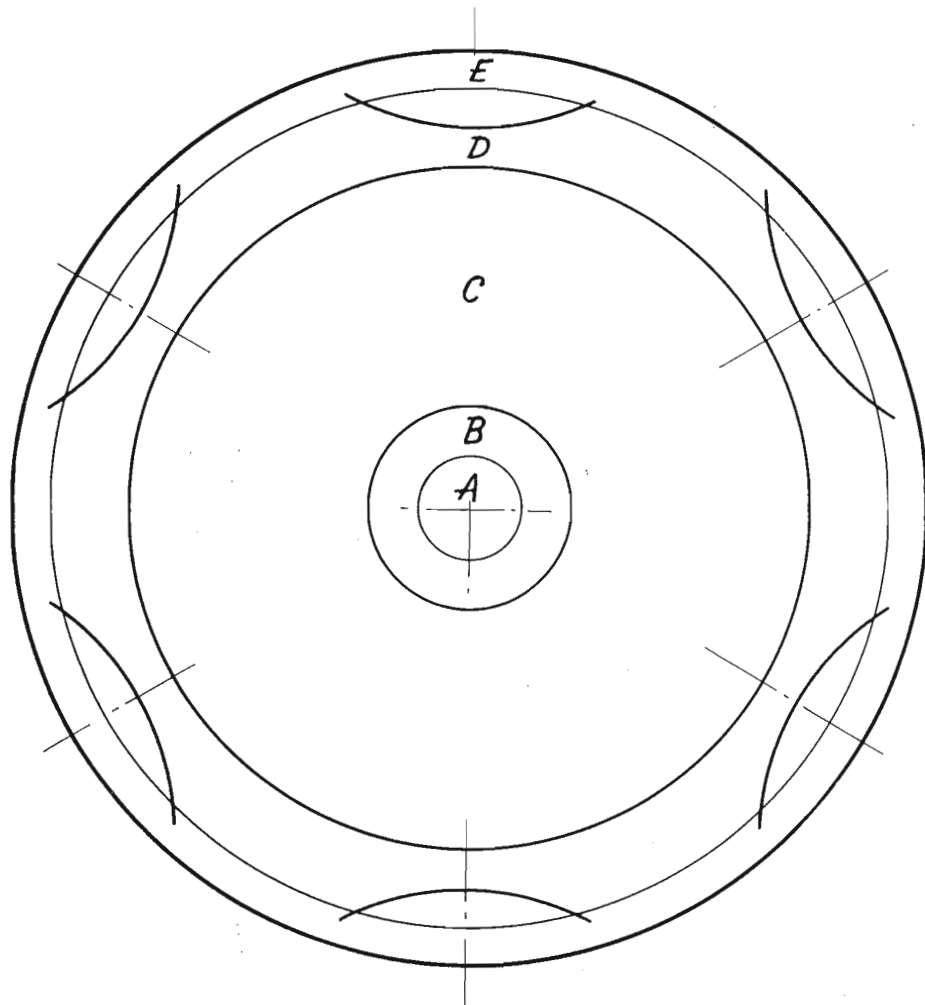

## BASIC ELEMENTS

- A—Center of Circle—  
Technical Traffic  
Distribution
- B—Center Core of Circle—  
Technical Areas
- C—Area of Circle—  
Studio Area
- D—Perimetrical Area—  
Production Area
- E—Perimeter of Circle  
Exit and Entry of  
Materials & Personnel

tion's growth over established time periods, its time on the air, and exact figures on programming as it affects live talent, film, remote and network programs, must be painstakingly studied. Other facts influencing planning are employment figures, areas and volume of the station, station location and character, number of sponsors and divisional budget figures. Comparative data on all television stations must be assembled for their possible bearing on any given tabulation.

The relationship between areas and volumes and the percentage ratio growth of each area, must be translated into production possibilities and better working arrangements. This can only be done by discarding the limitations of fixed and conventional building plant approaches. Therefore, beside his statistical knowledge, the television planner must possess plan-

ning faculties, ingenuity and imagination in addition to outstanding working knowledge of production techniques and operational policy of a television station plant.

With the help of such an analytical study supplied by the planner, the architect and engineer will then be able to produce designs based on firm facts and data. Only then will the client be guaranteed a plant in which all functions are provided with the necessary space and facilities properly integrated into the most efficient whole.

The assembly of these basic factors for such an analytical study takes time as it demands the assembly of all available data concerning television stations in general, the correct condensing of essential and fundamental material pertaining to a particular station which must be checked for

its character and exactness, and finally the analysis and interpretation of these factors before the detailed recommendations can be formulated.

## THE FUNCTIONAL TELEVISION STATION

The television operation is an intricate system of technical and production-wise problems. There are, however, three "Basic Elements" in this operation on which the planning structure may be developed.

These basic elements are:

- A. The operational area
  1. The technical traffic area
  2. The technical control area
- B. The production area
  1. The studios
  2. The production areas
  3. The production traffic areas
- C. The administrative area.

# THE FUNCTIONAL CHAIN

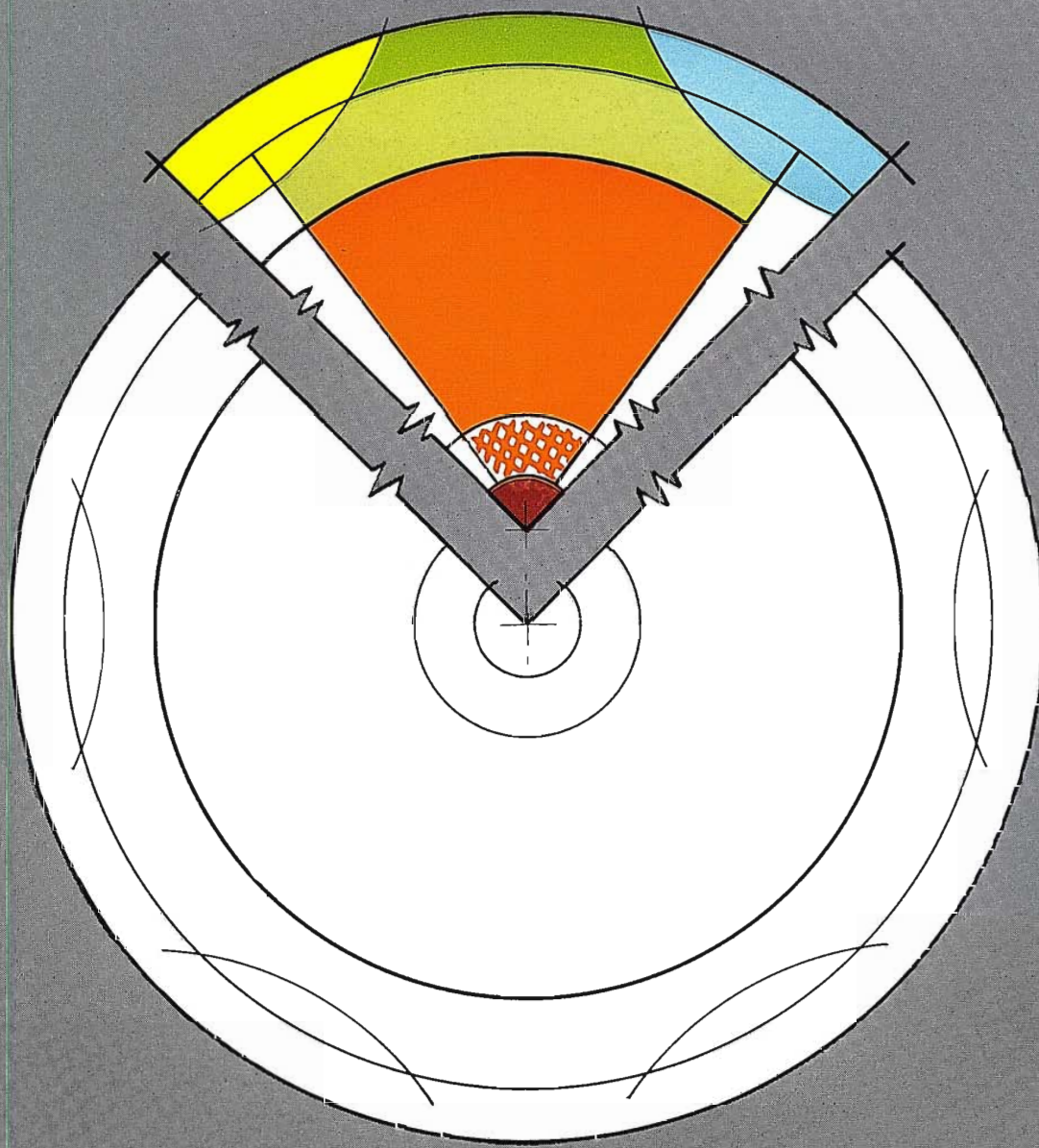

-  Production Personnel Traffic
-  Production Material Traffic
-  Studio Area
-  Production Areas
-  Studio Control Area
-  Technical Traffic
-  Aux. Areas Attached

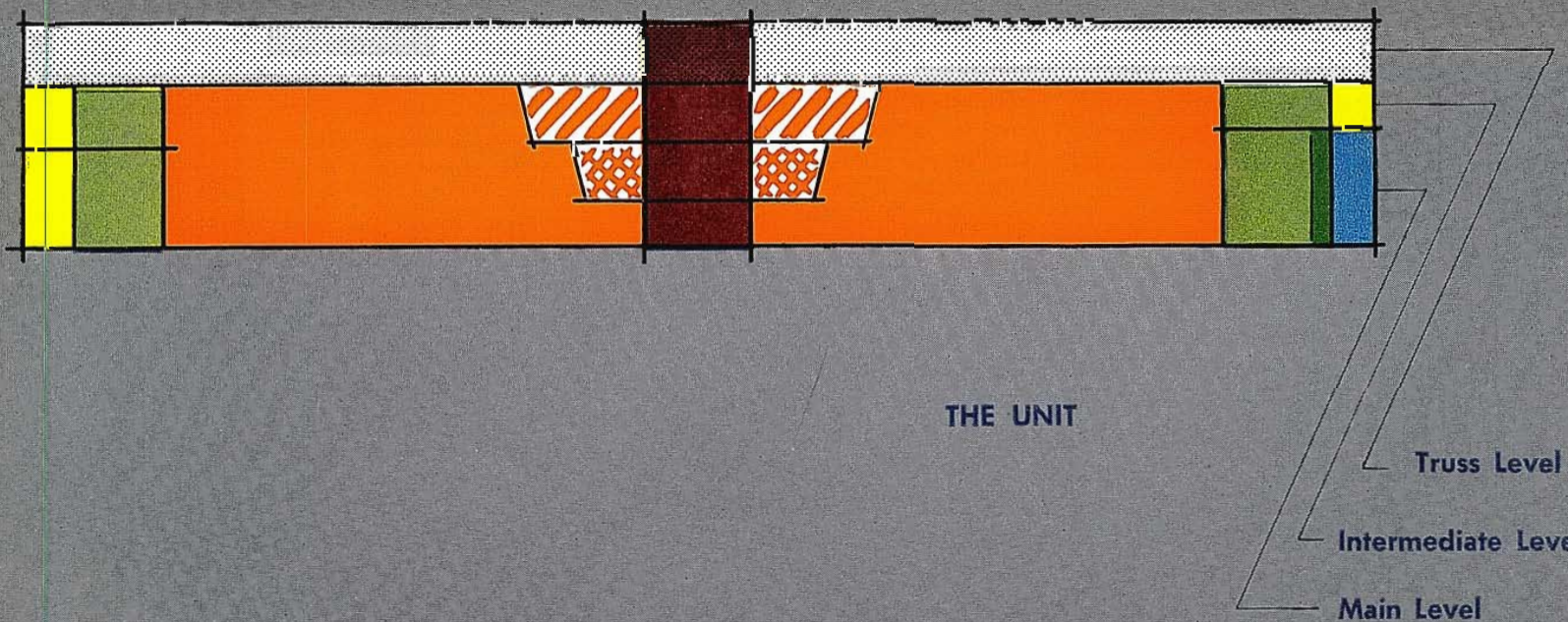

THE UNIT

Truss Level

Intermediate Level

Main Level

# HOW IT WORKS

- 1—Sightlines for Control Areas Radiating Outwards
- 2—Electrical Supply Systems Radiating Outwards
- 3—Personnel Production Entry Directed Towards Core
- 4—Material Production Entry Directed Towards Core

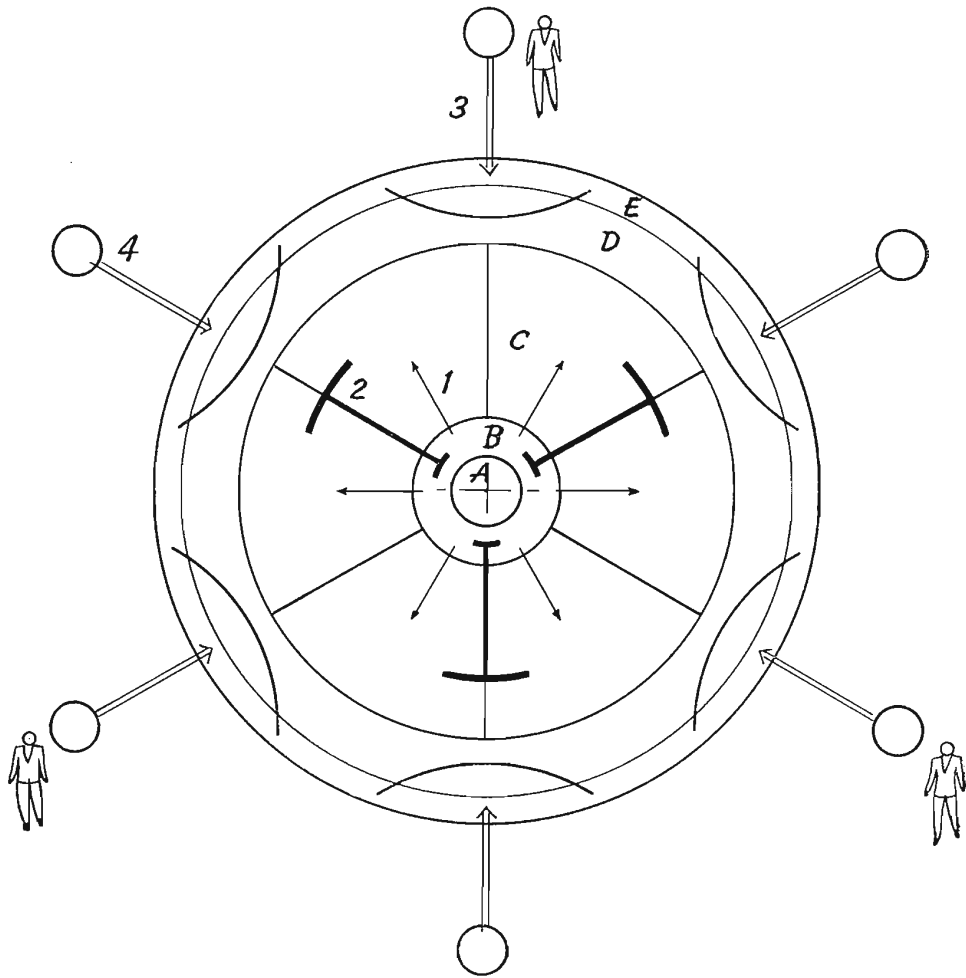

## THE OPERATIONAL AREA

Technical operations should be considered a main basic element. The technical traffic shall be separated, and confined to its own area. Provision for separate technical traffic is further necessary to eliminate bottlenecks and cross-traffic between operation and production. The technical traffic space should be arranged with care to provide direct exit and entrance to all technical areas, and to be large enough to permit personnel and material transportation. As such traffic will be of a vertical as well as a horizontal nature, it will make use of the fire stair tower as well as the elevators.

A technical core area should be provided and the technical control area, studio control rooms, master control rooms, announce booths, film projection rooms, etc., should be directly accessible from such a traffic core at different levels. This arrangement would provide, in addition to easy accessibility to all technical areas, the proper interconnection and quick interchange of personnel. Intercommunications between

technical areas will therefore be much facilitated. A vertical and horizontal duct system should be located in the same area. The electrical duct system should be laid out to permit the shortest possible runs radiating out from a centralized vertebra system. Such a core system will provide efficient and convenient maintenance and operation.

## THE PRODUCTION AREA

The functional separation of studios from other production areas must be realized for successful television operations. The present practice of using the high dollar value of the studio area as scenery, prop and equipment storage, should be abandoned. Ideally planned and adequate studio space is important because it is here that money is made and spent. Studio space should adjoin its control areas in such a way that sight lines and access to control areas are easy and efficient. Use of different floor levels should be considered in this planning stage, and is of such importance that it must be classified as a basic requirement.

Adjoining the studio area would be the other production areas. Some of the prop and scenery storage, and especially the equipment storage must be in the immediate vicinity and easily accessible. Dressing rooms, make-up rooms and other secondary areas need not, however, be in the immediate vicinity.

## THE ADMINISTRATIVE AREA

The administrative space should occupy the highest level, well separated from operation and production, and may be located in the structural truss area spanning the studio areas below.

## THE "CHAIN"

While the "Basic Elements" are the bricks with which the planner builds, the "Functional Chain" is the pattern he will apply. Such chains result from the interdependence and interrelation of complementary elements and areas and will read differently for each planning stage. Stage 1, for example, would be "Studio—Studio Control Area." Stage 2, which may be the



# APPLICATIONS

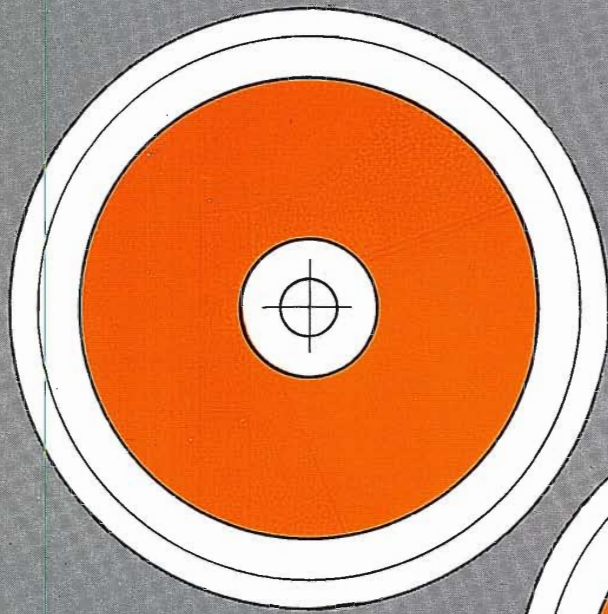

◀ The Basic Arrangement

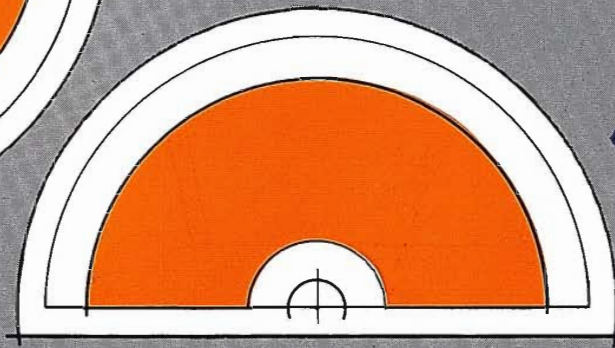

◀ First Simplification

Simplification Applied ▶

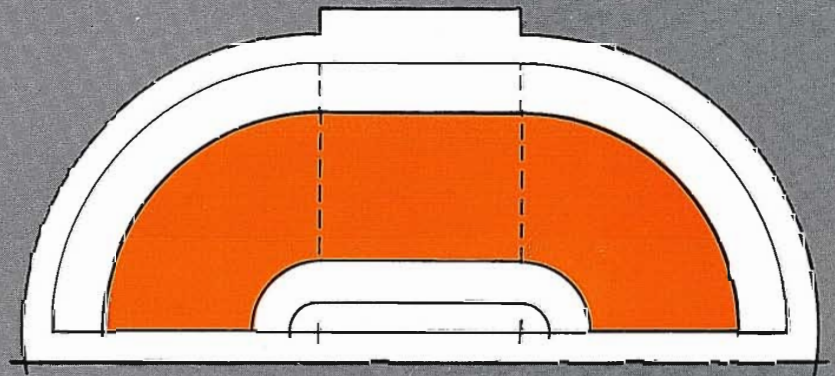

---

## DEVELOPMENT IN STAGES

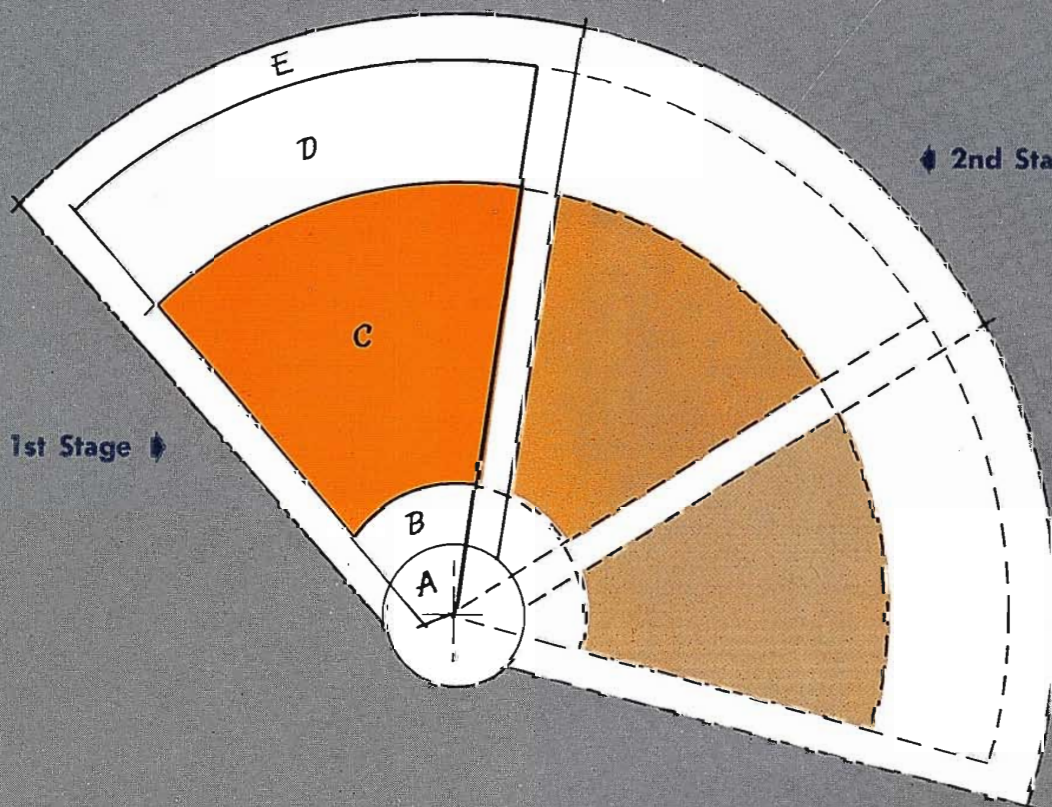

1st Stage ▶

◀ 2nd Stage

◀ 3rd Stage

## THE BASIC FUNCTIONAL CHAIN PRESERVED

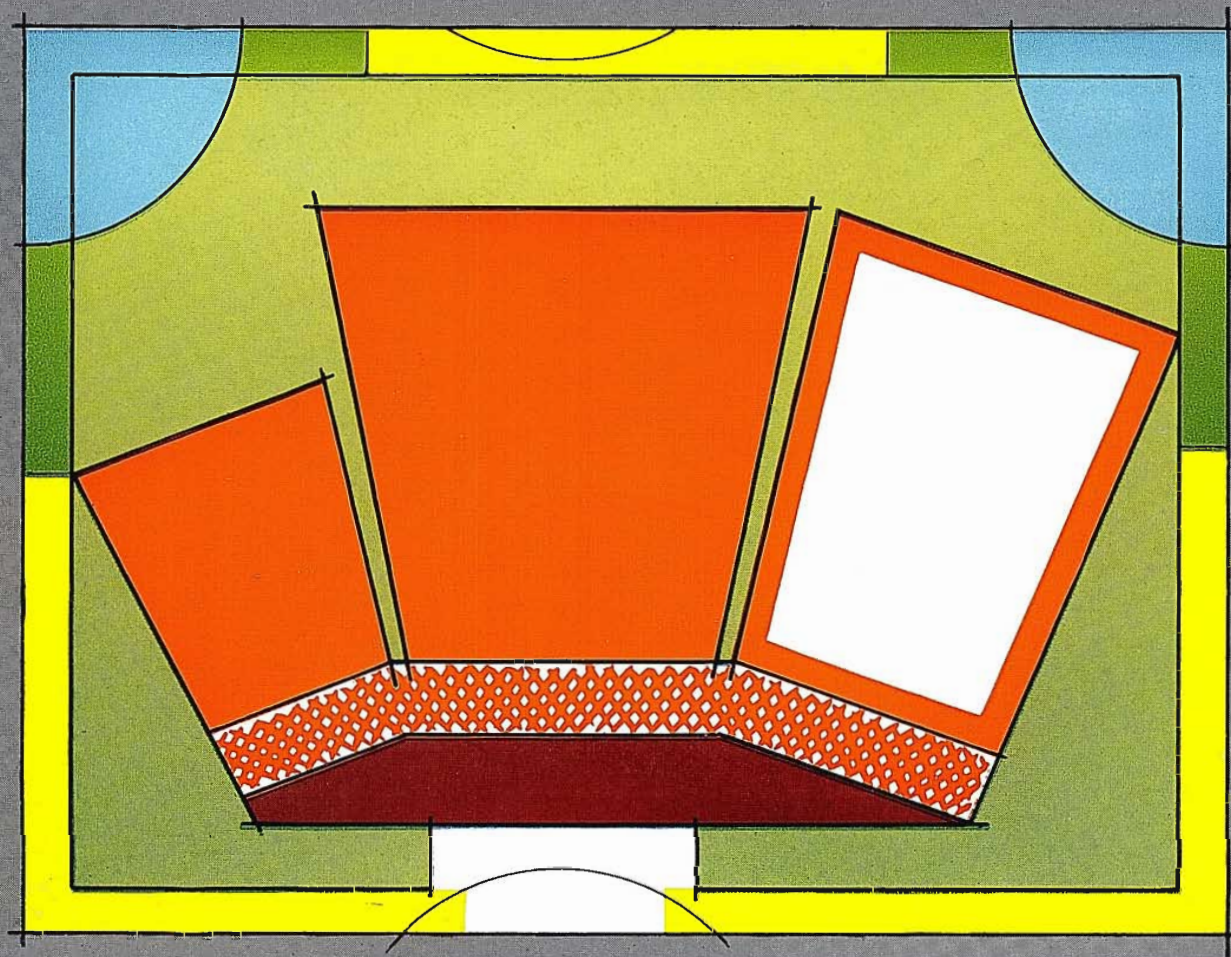

next stage in the progressive development of a station's facilities, might read "Production Area—Studio—Studio Control Area—Technical Traffic Area."

The proper distribution of areas to form such chains, besides providing for functional efficiency will also coordinate traffic and reduce intercommunication problems to the minimum. The various chains would then be linked closely together and integrated both horizontally and vertically. Once the general arrangement and pattern of these chains has been set, the planner, architect and engineer will then be able to determine very readily their proper working relation, shape, and dimensions.

Reconsidering the functional chain and the basic elements, the simplest and most efficient form of television development would be a circular horizontal plan. This plan would embody a two-level traffic pattern, and would, in general, offer the following advantages:

1. Functional simplicity.
2. Space economy.

3. Compactness of technical areas.
4. Centralization of all duct systems.
5. Accessibility of production areas.
6. Expansibility inside practical limits.
7. Flexibility of studio and production areas.
8. Lowest capital investment to enclose a given space.
9. Easy adaptability to a television station's growth—"Tempo of Adaptation."
10. Construction economy of a functional form modified only for aesthetic considerations.

These are a few of the pronounced advantages of the basic circular television plant design.

Starting with the circular arrangement, we can simplify it by using a half circle, and further modifying it by interposing a horizontal strip. This solution would still offer a well coordinated television plant design with all the inherent advantages of flexibility and expansion. For new stations, the sectional development may be the most

advantageous solution. This would permit the development of the station in stages suited to the tempo of adaptation. Standardization in structure and building elements moreover can easily be achieved by architects and engineers.

Applications of the basic circular plant development can be made to most square or rectangular forms as long as the functional requirements do not seriously interfere with building limitations. The planner may have to scale basic function against building limitations to provide sound planning recommendations for the architect and engineer. Thus, since these basic arrangements can be readily adapted to conventional space and architectural limitations, there can be no excuse for improper planning.

In practice, complete circular development is possible only where a large completely new station design is to be constructed. Nevertheless, modifications of this basic solution can be applied to many existing alterations and new buildings within existing and imposed limitations.

# EMPIRE STATE TELEVISION

Progress toward completion of the Empire State Building Multiple-Station Antenna took another forward jump recently when the old 67-foot TV antenna was dismantled and work on the new tower started, without interruption of television service by any of the participating stations. Temporary antennas which were previously installed will continue to be in operation while construction work is underway.

Highlights of the steady forward strides taken in the mammoth project were: (1) erection of two temporary TV antennas to accommodate ABC (WJZ-TV) and NBC (WNBT); (2) installation of new steel reinforcements which will eventually support the new 217-foot TV tower; (3) erection of scaffolding, protective screens and working space at three levels; and (4) the section-by-section "cutting-away" of the old 67-foot TV antenna with acetylene torches.

A "word-picture" story of the construction work and "tearing-down" of the old antenna is given in the photos on the following pages. The job of constructing new reinforcement steel at the top of the building was, in itself, an ambitious project. This was completed by an American Bridge Company crew which also has completed other phases of the erection and dismantling work. As the photos illustrate, the old 67-foot antenna was lowered gradually, as three-foot sections were cut away. These sections were in turn lowered by means of elevators to the 85th floor where larger freight elevators "took over".

Meanwhile, engineering test and development work by RCA engineers at Camden, N. J. (see photos next page) continues at full speed. Full-scale towers are being used for complete engineering performance tests, which include such work as decoupling measurements between antennas, antenna impedance characteristic measurements and similar tests which will assure the proper operation of five TV antennas from one supporting structure. The main function of the full scale tower task will be that of determining as nearly as

possible the actual decoupling between the separate TV antennas. This measurement will be made with the final antennas which will be placed on the tower on top of the Empire State Building.

Towers are arranged to support adjacent pairs of antennas in the same manner in which they will be located on the building. For instance, to determine the coupling between antennas for Channels 2 and 5, the Channel 2 antenna will first be energized with a signal source on Channel 2, and the amount of energy received by the Channel 5 antenna from Channel 2 will be measured and recorded. Then the opposite arrangement will be made; that is, to energize the Channel 5 antenna with

the Channel 5 signal and measuring the amount of Channel 5 signal picked up by the Channel 2 antenna. In a like manner, all of these adjacent antennas will be tested.

The overall, multiple-antenna project when completed will provide better television transmission and greater coverage for the metropolitan area. Also, the centralizing of several antennas at one site will simplify orientation of individual "home-receiver" TV antennas. The new 217-foot TV antenna will provide facilities to accommodate WCBS-TV, WABD, WJZ-TV, WPIX and WNBT television stations.



FIG. 1. View of the top portion of Empire State building showing temporary antennas located at each side. Note that photo was taken before old 67-foot TV antenna (center) was taken down. The three platform working levels provided are visible. Photo was taken from the Metropolitan Life Insurance Building with a 40-inch telescopic lens.



FIG. 2 (above). In this photo, Ray Corbet, American Bridge Company foreman, fastens lines to the 75-foot NBC temporary antenna which towers above: (left to right) the Chrysler Building with WCBS-TV antenna, Daily News Building with WPIX tower and the United Nations Building.

FIG. 3 (below). At Camden, RCA Engineer Howard King at right and assistant are shown making impedance measurements on the Channel No. 7 antenna elements.



FIG. 4. In this photo, Richard Wright, RCA Engineer, is shown directing the assembly of the four-layer Super Turnstile Antenna for Channel No. 4.

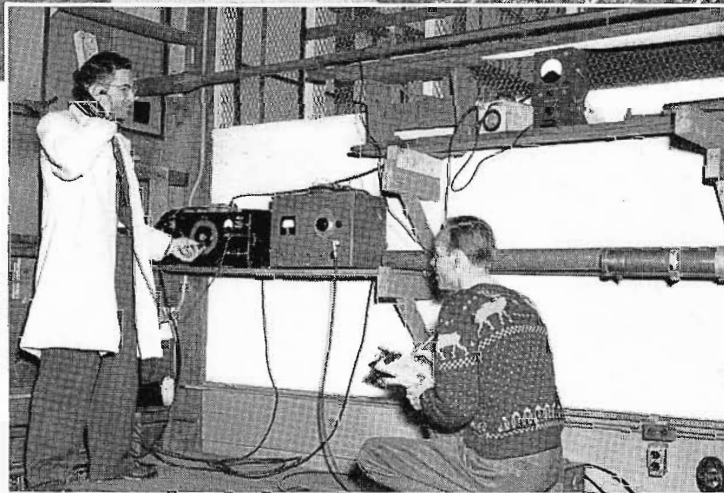
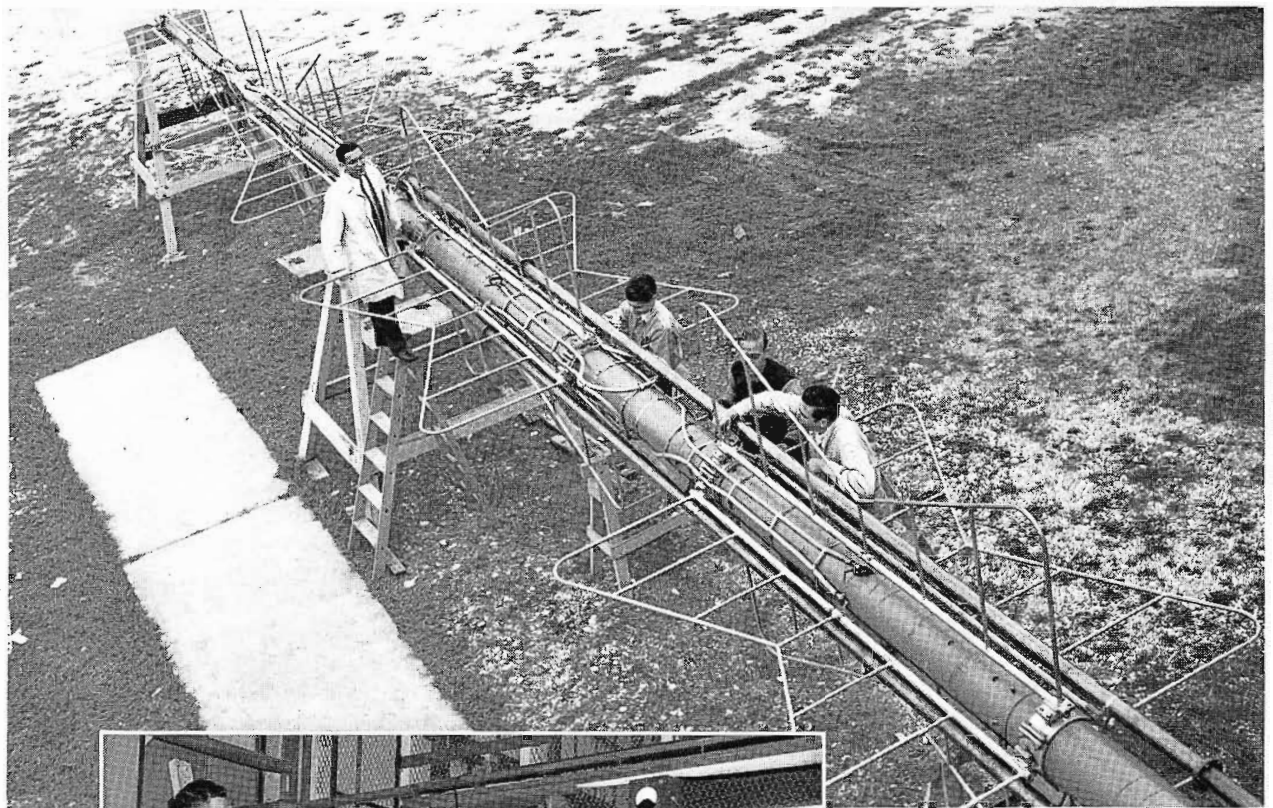

FIG. 5. Richard Wright and Joseph Blake are shown making characteristic impedance measurements on the Super Turnstile Antenna pictured in Fig. 4.



FIG. 6. Partial view of the engineering field laboratory showing the Channel No. 7 antenna under test in the foreground and Channel No. 5 antenna in background. Near building, Channel No. 4 Super Turnstile is visible.



4 Here at the 96th floor, American Bridge Company steel workers are fastening new steel reinforcements to provide additional strength to accommodate increased activity, loads overhead, and the future 217-foot tower.



2 A three-story scaffold erected atop the Empire State building was necessary to provide adequate working space. Here, steel workers are shown completing the top working level, 1300 feet above the street level.

## “ACTION-PHOTO” SEQUENCE SHOWING

5 Next, after turnstile sections came down, the mammoth job of removing the supporting pole was tackled. (“Spider” Kelly is fastening “rigging” to old tower.) Protective screens avoid falling material and injury.

6 In this photo, American Bridge Company steel workers are securing rigging and hoists preparatory to lowering the old antenna. A special boom holds the old antenna which is lowered as each pole-section is removed.

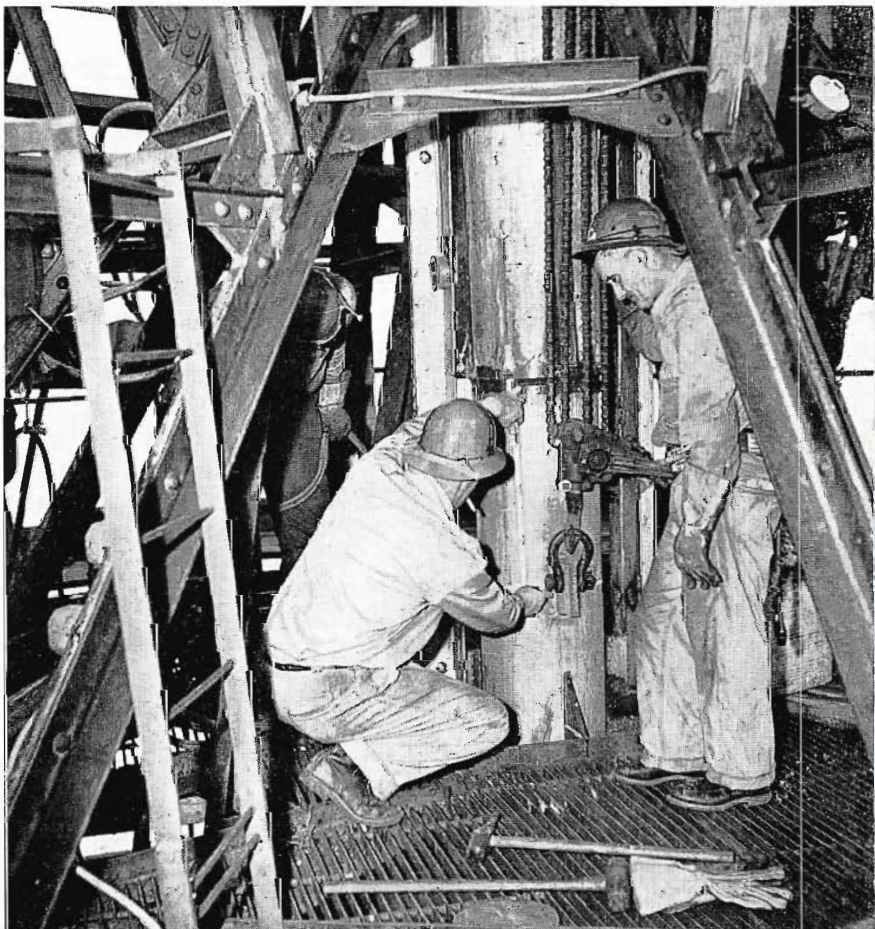
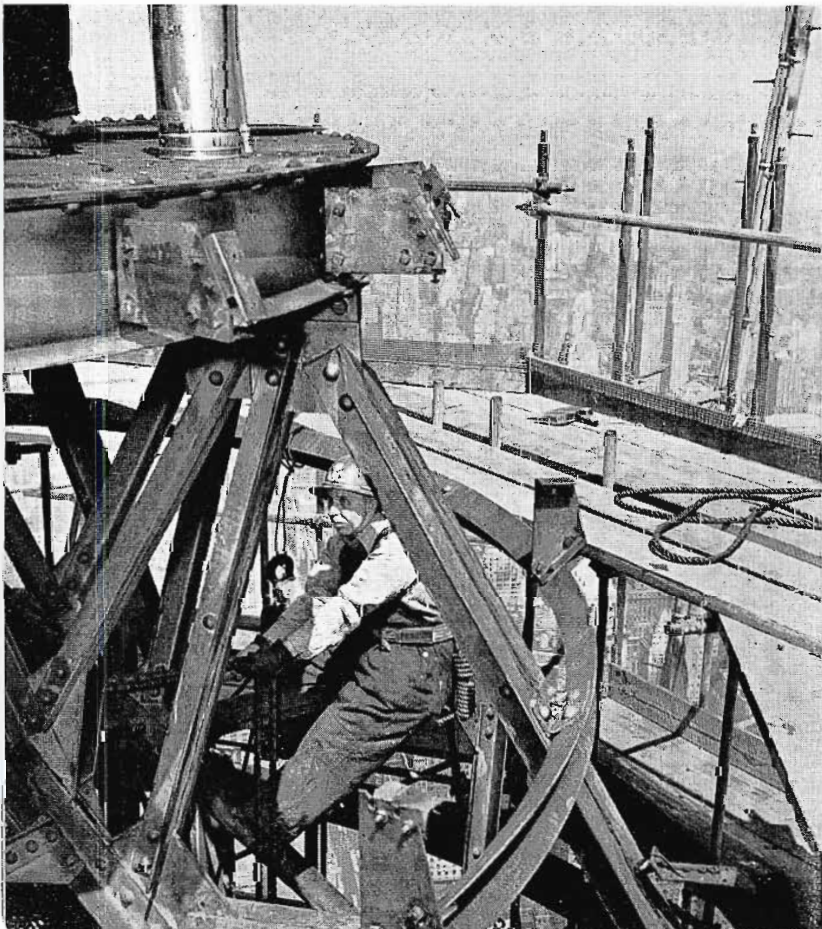



3 Before dismantling of the old TV antenna began, temporary antennas were erected to insure continuous service. Pat Corbet (right), 57, and son, Joe, 32 years old, are fastening transmission line on NBC's temporary antenna.

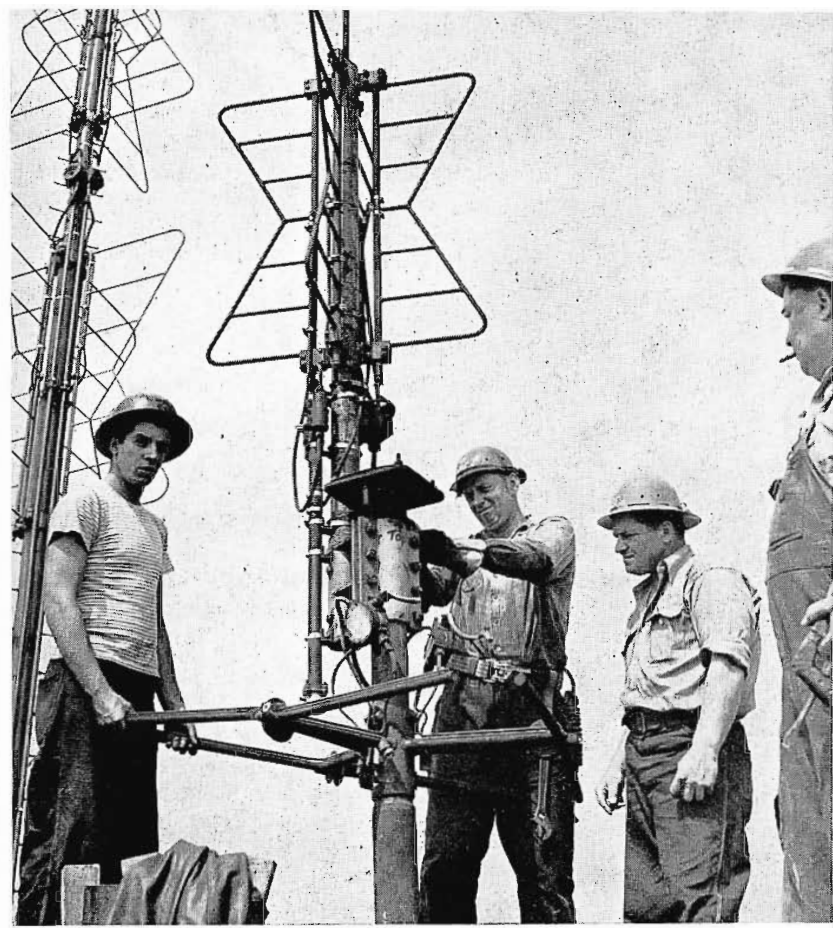

4 Next, came the "tearing-down" process of the old NBC, 4½ ton, 67-foot TV Super Turnstile antenna. American Bridge Company steel workers are shown at work during the antenna dismantling procedure.

## CONSTRUCTION PROGRESS AT 1300 FEET "UP"

7 Section-by-section the old supporting pole was "burned-away" by the use of acetylene torches. Note that cable and pulley rigging is attached to the 400-pound section for safely lifting and "lowering-away".



8 As each section was burned away, it was lowered (by a specially erected boom) to the 102nd floor. Each section was then carried in the elevator shaft to the 85th floor, where the freight elevators did the rest.

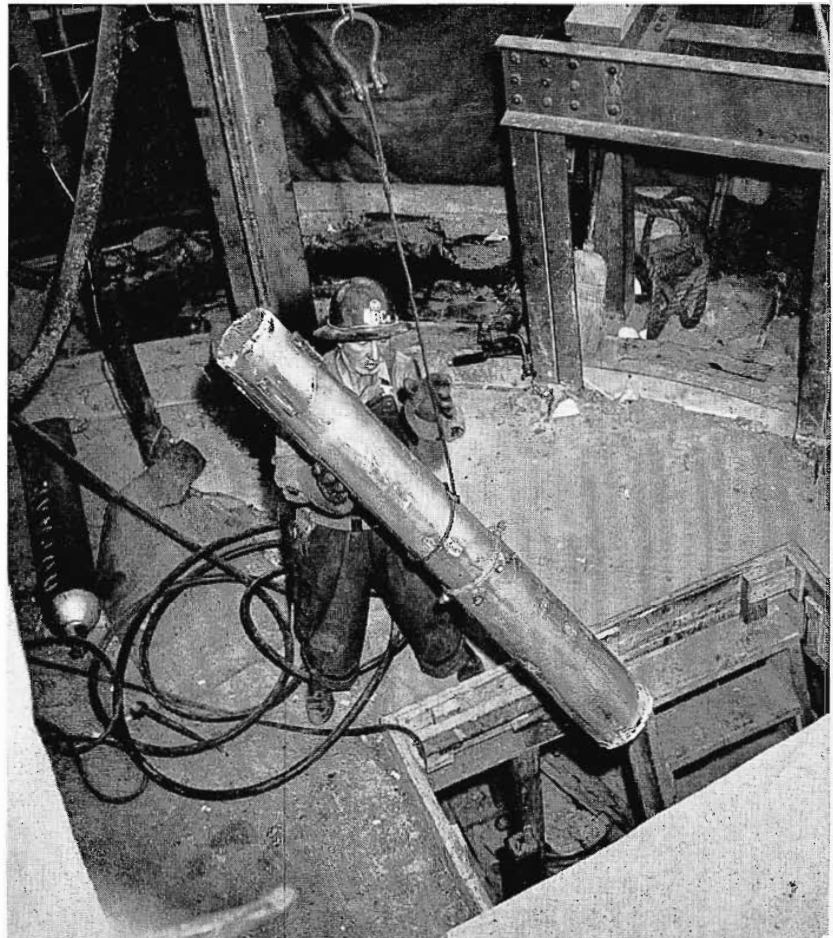

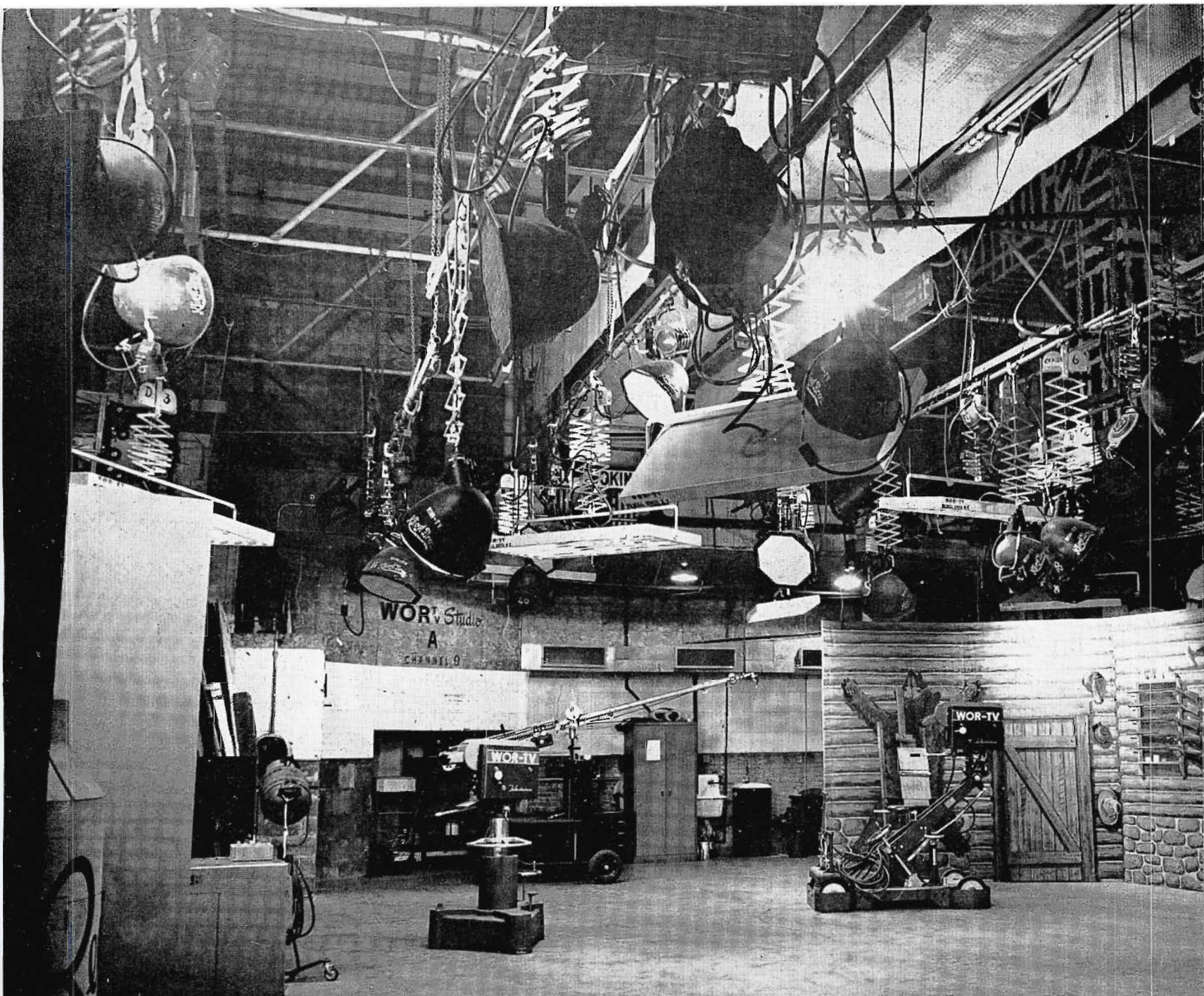

# WOR'S TV STUDIOS

WOR-TV's new television studios on West 67th Street in New York incorporate not only the latest types of television studio equipment, but also some new and different ideas in studio and control room arrangements, all of which make a marked improvement in efficiency and flexibility of operation. The "Television Center" takes in the width of an entire city block between 66th and 67th Streets. WOR-TV's studios and offices are constructed on the 67th Street side of the "Center".

**By NEWLAND F. SMITH**  
 Engineer-in-Charge of Television  
 WOR-TV, New York

The studios are the result of over a year's engineering planning and construction, all co-ordinated by the Television Engineering Department of WOR-TV. Initially the station, whose transmitter and 810-foot tower and antenna are located at North Bergen, New Jersey, went on the air October 5, 1949, from its New Amsterdam Television Theatre Studio and remote pickup points. After four months

of operation in this manner the new studios and master control facilities at 67th Street were completed and opened February 1, 1950. Since then, most of the studio programs on WOR-TV and all film camera work has originated at this point.

## Building and General Facilities

The building which WOR-TV chose for its studio and master control facilities is the 67th Street half of the old New York Riding Academy building which ABC initially purchased for their television cen-



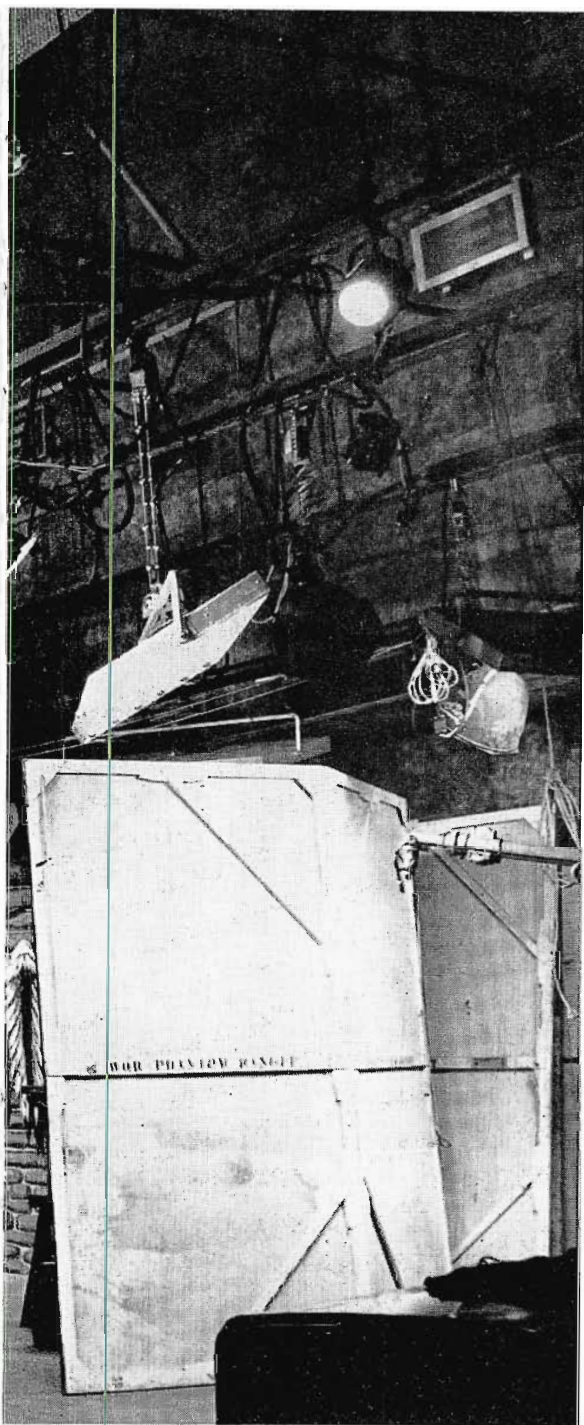

FIG. 1 (above). Overall view of WOR-TV studios located at "Television Center." Occupying nearly 10,000 feet of floor space, the area is generally utilized as a two-studio setup, studio "A" at left, and studio "B" at the extreme right.

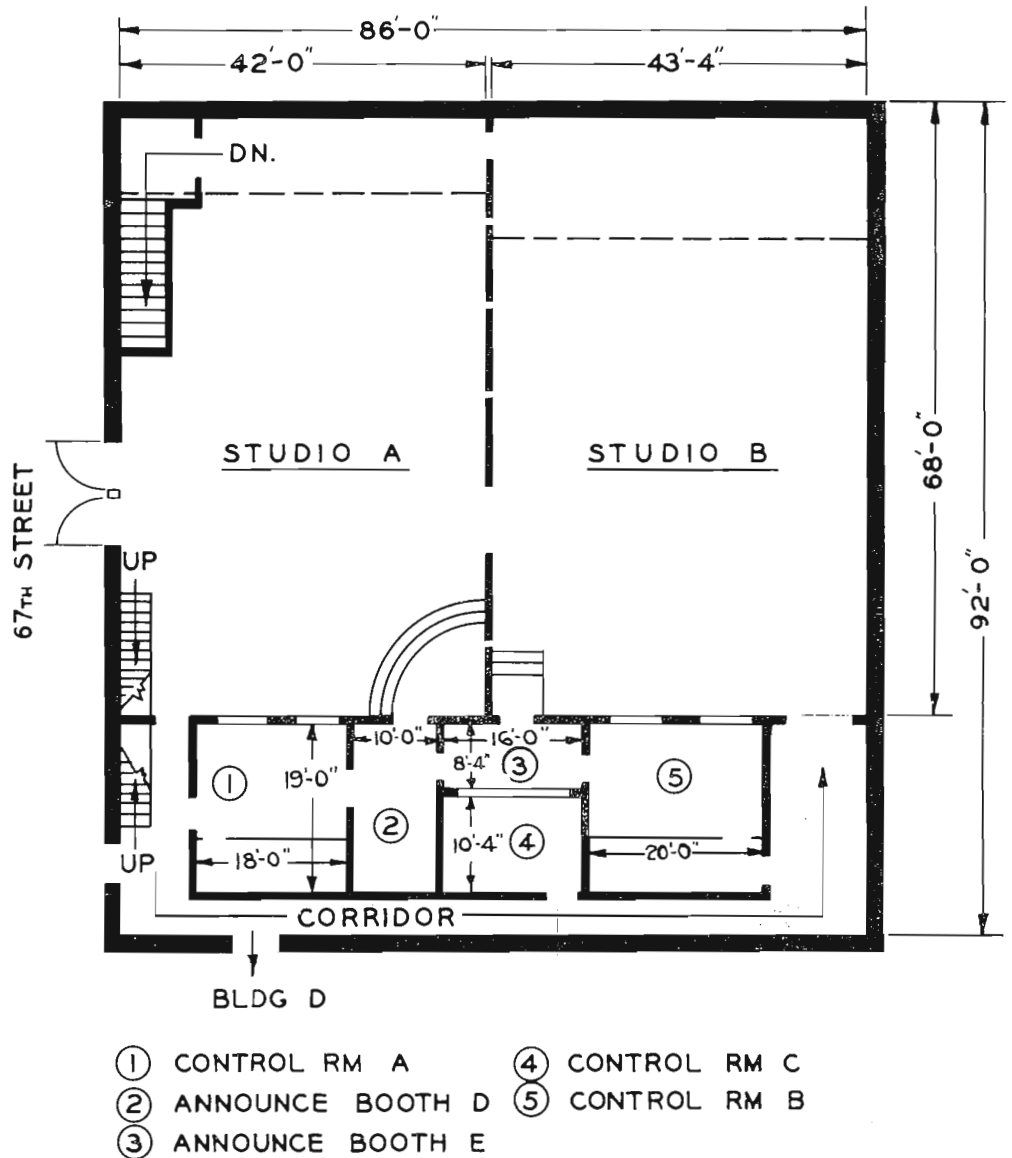

FIG. 2 (above). Plan layout of first floor showing the WOR-TV studios. Space is utilized so that two large studios (each approximately 42 feet by 68 feet) are provided. Control Rooms and Announce Booths are located as shown above.

ter. The floor space was approximately 90 feet by 90 feet with a peaked roof which gave a maximum ceiling height of 45 feet. In this space WOR constructed two large television studios (each having approximately 3000 square feet of floor space), two announce studios, three program control rooms, master control, and projection room facilities (sometimes termed Studio C).

In addition, a small building adjacent on 67th Street, which was formerly a carriage house, was made into offices for the

station operating personnel and dressing rooms. The first floor studio and control room arrangement is shown in Fig. 2 with the space over the studio control room being divided up as shown in Fig. 8 for camera control center, master control, and projection facilities.

Facilities are so arranged that any combination, up to a maximum of eight of the eleven local sources of signal (studio and film cameras) may be previewed and switched on the program line in any of the three program control rooms. In addition,

up to three remotes may be set up for previewing and switching at one time in any of the three control rooms.

#### WOR-TV Studios "A" and "B"

The two large studios, "A" and "B", each 42 by 68 feet, comprise the playing area available at 67th Street. As may be seen from the accompanying photos and floor plans, the two studios are, in effect, one very large room which lends itself to many different flexible studio sets and arrangements. Usually, the overall space is devoted to the studio "A" and "B"

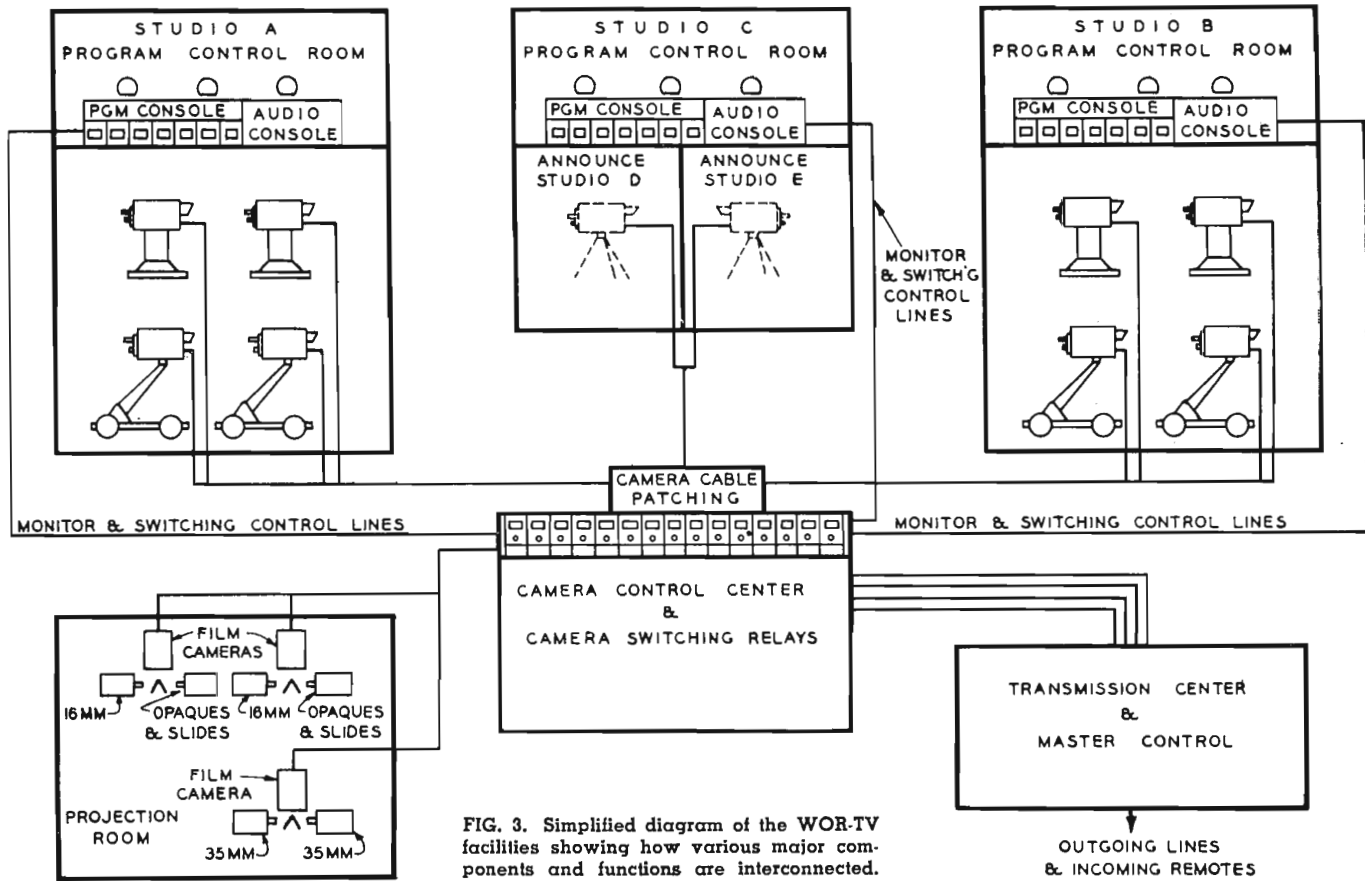

FIG. 3. Simplified diagram of the WOR-TV facilities showing how various major components and functions are interconnected.

FIG. 4 (below). A typical studio setting at WOR-TV. In this setup, a portion of studio "A" is being utilized.



## WOR-TV STUDIOS "A" and "B" (Continued)

setup, however three sets or shows can easily be in motion at the same time.

Each studio has a separate control room, and the control rooms of "A" and "B" overlook the studio floor. Studios "A" and "B" each contain four studio cameras, two mounted on crane type dollies, and two on pedestal type. A microphone boom and perambulator are also located there. In addition they are provided with a possible maximum of 42 microphone outlets.

The arrangement of the studios in this building incorporate several new and novel ideas. First, is the separation of the cam-

era control operators from the program direction and switching center. Here the camera control operators are centrally located (for all studios) in one room called the Camera Control Center. In this way the program director is unencumbered by any distraction which might occur from working over the shoulders of the technical operating personnel, or from any confusion which might arise from their being in the same room.

With this system, the program director has directly in front of him, at his console, monitors on each of his local cameras

plus two preview monitors for switching up the cameras from some other studio which might be used as part of his particular program. The program consoles used in these "Program Control Rooms" are all made up specially, using seven of the standard TM-1A program monitors. In addition, the switching control panel is located on this desk for the video switcher who sits alongside of the program director.

By centrally locating all camera control units in one place further advantages were realized from the technical point of view. First, maintenance operations on the equipment are no longer hampered (during rehearsal and program periods) by the presence of program personnel in the same

*(Continued on page 51)*

### WOR . . . ONE OF AMERICA'S PIONEER STATIONS

Every hour, on the hour, WOR announcers identify the station as "WOR, One of America's Great Stations." It is a claim that has never been disputed—and is unlikely to be in the future, as the accompanying story on WOR-TV studio facilities will indicate.

WOR may also lay claim to being one of America's pioneer stations. It was established in February 1922 by Bamberger's

Department Store in Newark—as a promotion for the sale of radios. The first transmitter was a reconditioned DeForest 250 watt located on the roof of the store. Operator of this rig (see illustration below) was a young man by the name of Jack Poppele. A year later, when a brand new 500 watt transmitter (one of the first commercial transmitters to be specifically designed for broadcast use) was installed, Jack was put in charge of technical operations. Today he is Vice President of WOR, a director of the Mutual Broadcasting System and the President of the Television Broadcasters' Association. The industry's "oldest" station engineer,

in point of continuous service with one station, he is also its best known. He has served on many technical committees of the IRE, the SMPE, the Acoustical Society and the VWOA. Recently he was appointed "Head of Communications" for New Jersey State Civilian Defense Administration.

During Mr. Poppele's twenty-eight years at WOR he has seen the station grow—to 5,000 watts in 1927, to 50,000 watts in 1935—through Apex, Fax, FM and now TV. In every forward step WOR has been a pioneer—in the lead in progress, programming and prestige.

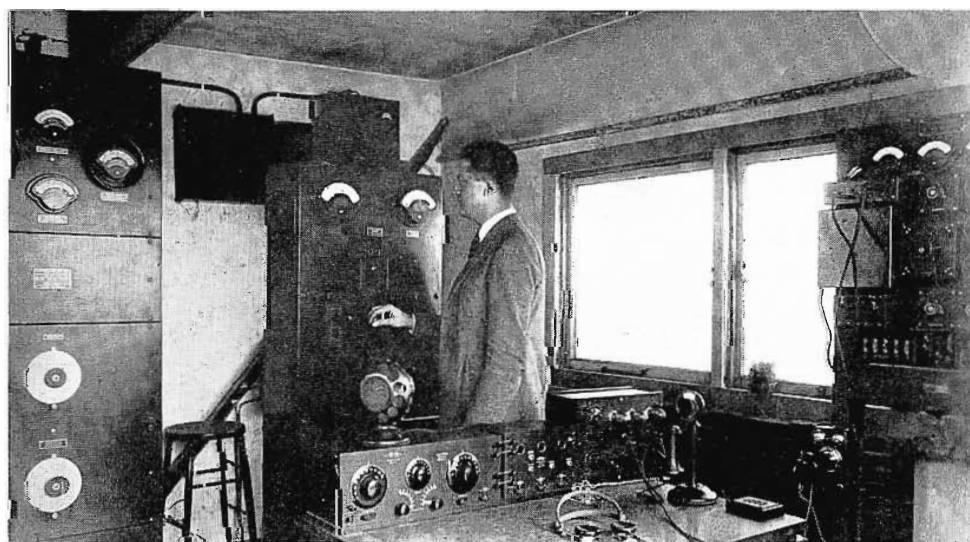

FIG. 5 (above). WOR's first transmitter installation on the roof of Bamberger's Department Store in Newark, February 1922, J. R. Poppele, engineer, at the controls.



J. R. (Jack) Poppele, Chief Engineer and Vice President of WOR and WOR-TV.



## WOR-TV STUDIOS "A" and "B" (Continued)

room. Secondly, the flexibility of operation is greatly increased. For example, any combination of the eight studio cameras and three film cameras can be used together on any program switched through any of the program control rooms. This flexibility is further increased by the use of a camera cable patch panel in the camera control center, enabling any of the studio camera controls to be patched to cables leading to any of the main studios or announce studios. Thirdly, it is possible to realize a saving in the number of operating personnel assigned for the camera control operation with this new arrangement. In addition, replacement of equipment is greatly facilitated by this centralized operation.

### Studio Lighting

A very flexible studio lighting system has been installed in each studio. This permits the use of slimline fluorescents as well as incandescent spots, scoops, and strips in any combination required for a particular show. The fluorescent lighting is provided to give a good basic lighting for the scene with the incandescents to be used for fill-in and modeling.

Control of all the lights is normally done from four portable switchboards on the catwalk in each studio. In this way most of the lighting cables and distribution circuits can be kept off the studio floor. If, however, it is required for some small scene to have the control on the floor, one of the portable boards may be brought down and plugged into an outlet provided in each of the four corners of the studio. Dimmers may be used in series with the circuits when so required. All of the slim-line fixtures, and a large number of the incandescent fixtures are supported on pantograph "sky-hooks" which make it easy to adjust any lamp.

In addition to the lighting fixtures provided in each of the two large studios, there is provision for plugging in 5 kilowatts of lighting fixtures in each of the two announce studios when it is required to use a camera there.

FIG. 9 (at right). Partial view of studio "B", looking into WOR-TV control rooms. Visible overhead is the WOR-TV studio lighting arrangement made up of slim line fluorescents and flexible scoops.

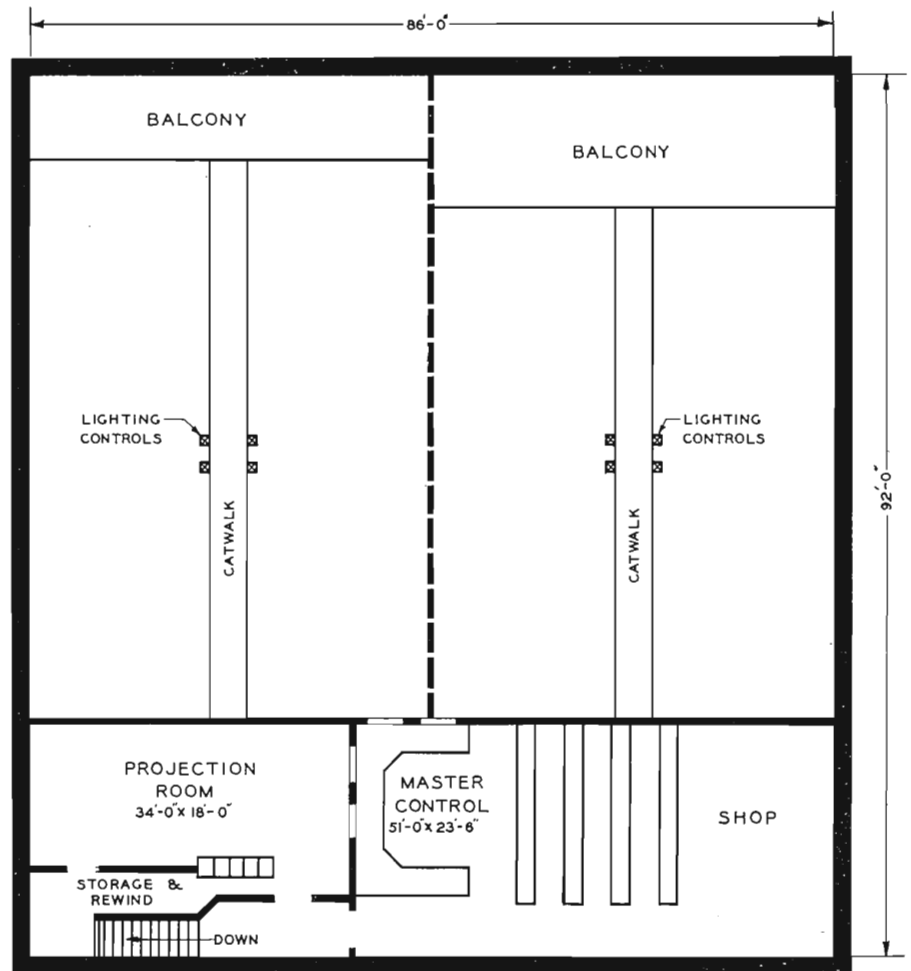
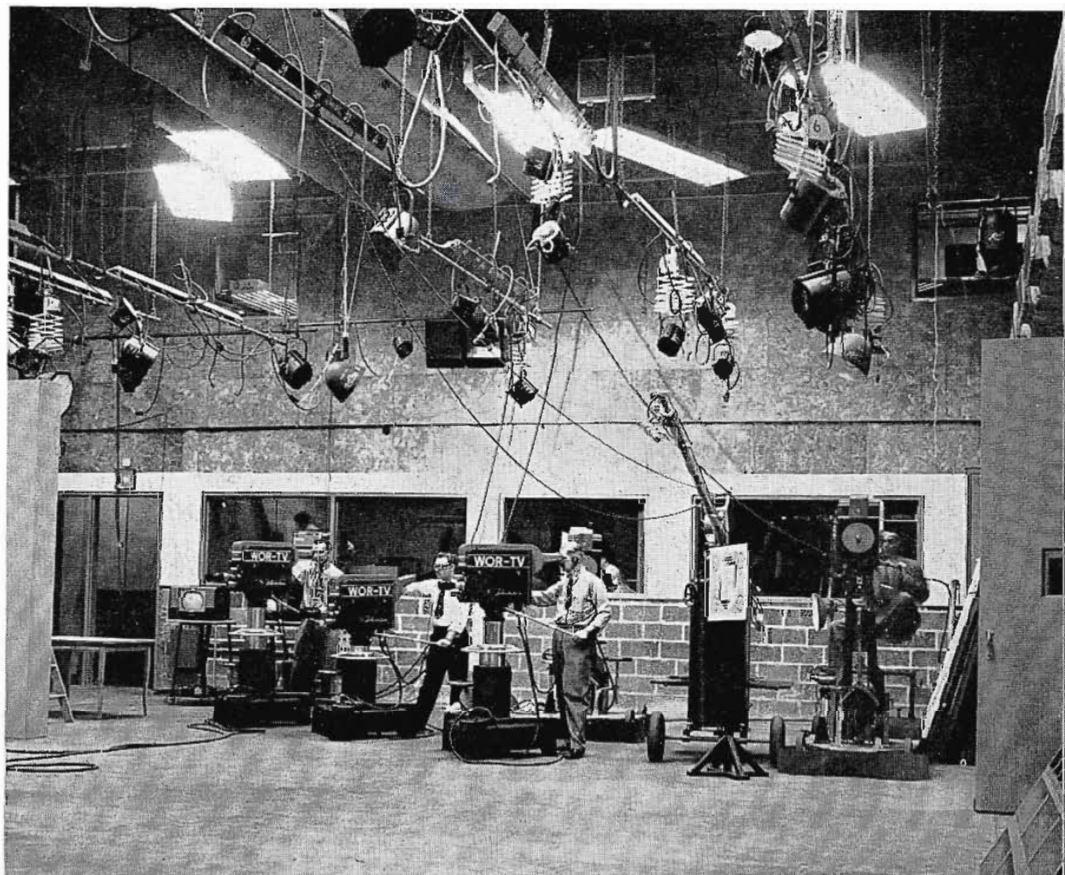
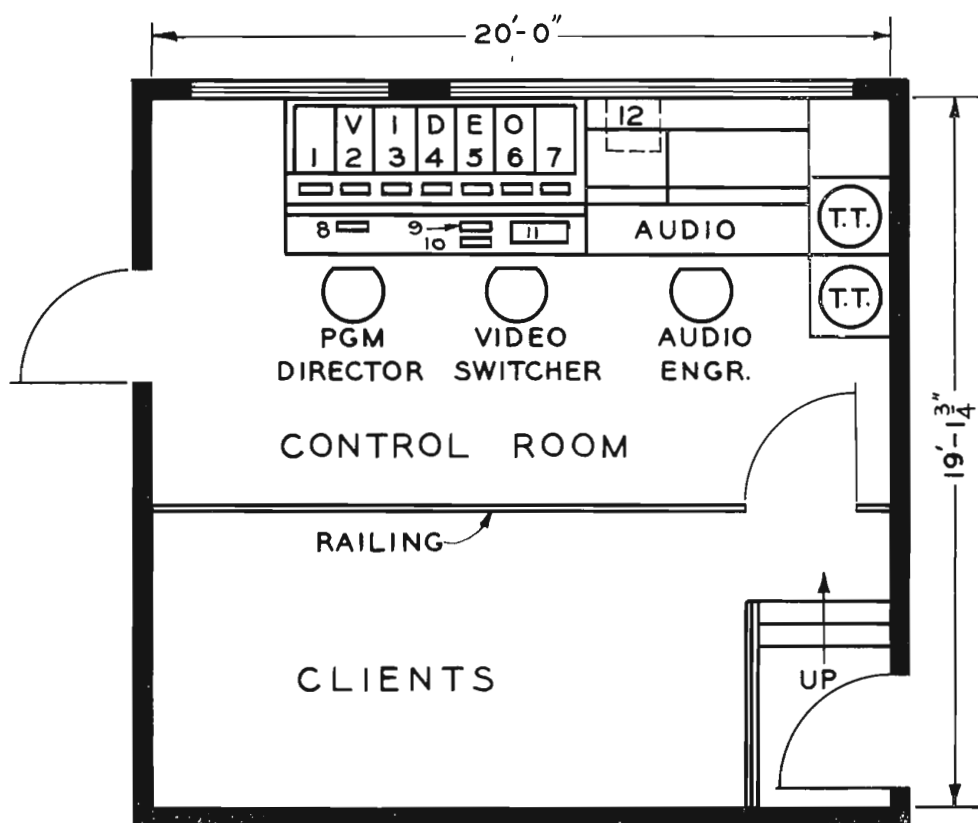

FIG. 8 (above). Plan layout of the second floor showing upper part of studios where lighting equipment is located, projection room and master control rooms.



# STUDIC

# WOR-TV STUDIO PROGRAM



Three program control rooms are provided at the 67th Street Studios, all of which are identical as regards facilities. One of these control rooms is used normally with each of the two large studios—Studios A and B. The control room floor level is about two feet above the studio floor. A large window from the control room permits good visibility into the studio.

FIG. 10 (at left). Typical floor plan of one of WOR-TV studio control rooms. All three control rooms are practically identical as to facilities. Video console components: 1. Preview Monitor—1. 2. Camera Monitor—1. 3. Camera Monitor—2. 4. Camera Monitor—3. 5. Camera Monitor—4. 6. Line Monitor. 7. Preview Monitor—2. 8. Director's Intercom Panel. 9. Projection Room Remote Control. 10. Technical Director's Intercom. 11. Switching Panel. 12. Receiver Monitor.



FIG. 11. View of Control Room "A" showing the WOR-TV Program Director's Console at left and the Audio Console at right.

## CONTROL ROOMS "A", "B" and "C"

The third control room (Studio C Control Room) is normally used for handling of remote programs or film programs. Film inserts on remotes are easily handled in this control room by routing the remote signal through the Studio C switching system. In addition, all station breaks and film spot announcements introduced in the station break period are handled in the Studio C Control Room. Studio C Control Room is therefore one of the busiest spots in the station, and is manned at all times when the station is on the air.

### Program Relay Switching Accomplished by TS-20A System

Each of the studio camera switching systems consists of a sixty button switching control panel located on each of the program consoles. *These buttons merely*

*operate d-c control circuits that switch the video by means of the TS-20A switching relays located centrally in the Camera Control Center for all studios.* Each switching control panel contains five horizontal rows of buttons which fundamentally allow for twelve inputs and five outputs. The twelve inputs provide normally for eight local cameras, that is, video signals without sync, three inputs for composite or remote signals, and one input which is the "Effects" input. All of the inputs appear on the coaxial patch panels in the Camera Control Center, and therefore any of the three camera switching systems can be set up with any of the camera circuits or other signals required for a given programming. The five outputs of the camera switching relays are generally used as follows:

The lower bank selects any one of the input signals for the program output circuit for that studio, and is set up for "over-lap" switching. The next two banks are used for setting up the so-called "Effects" amplifier inputs. That is, any two of the inputs may be selected for feeding a mixer amplifier, for producing lap dissolves, super-positions, and fades. The fader control is located directly to the right of these "Effects" buttons. The upper two rows of buttons are used to select inputs to the two preview monitors located at either end of the program console.

In summarizing the available camera switching sequences, any of the following specific combinations are obtainable with the camera switching equipment used (provided Master Control has patched in the required signals).

*(Continued on page 54)*

FIG. 12 (below). Studio Control Room "B" during program operation (Program Director at left watches seven monitors; Preview 1, Cameras 1, 2, 3 and 4, Preview 2 and Line Monitor). Video Switcher sits at director's right and audio engineer at audio mixing controls.



# WOR-TV STUDIO PROGRAM

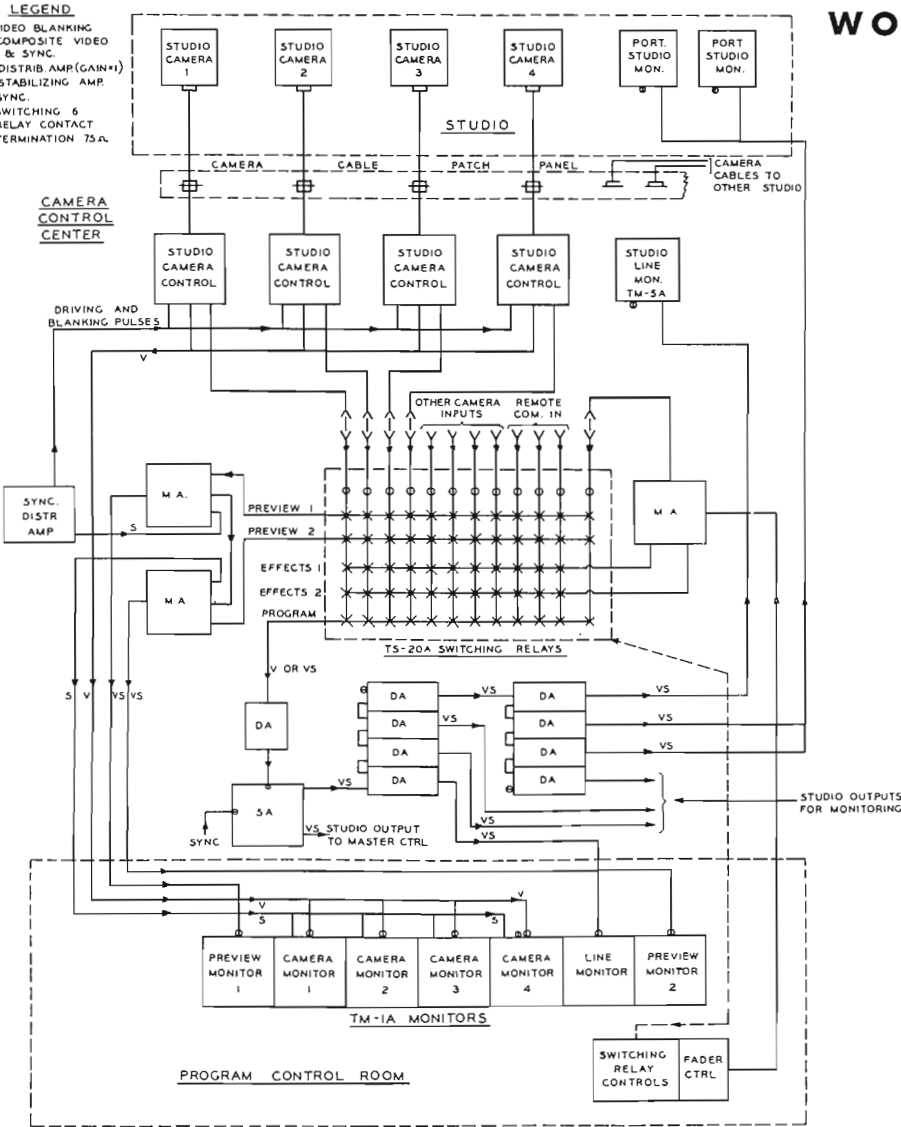

## Switching Possibilities Available

### A. PROGRAM BANK

This controls the signal which is sent out to Master Control.

1. Instantaneous switch between any two studio and/or film cameras.
2. Instantaneous switch between any local camera and a remote signal.
3. Instantaneous switch between any two remote signals.
4. Instantaneous switch between any local camera and an "Effect" as set up on #12 input (such as a superposition of any two local cameras).
5. Instantaneous switch between any remote signal and an "Effect" as set up on #12 input.

FIG. 13 (left). Simplified schematic of the studio program switching system employed at WOR-TV.

FIG. 14 (below). Closeup of the WOR-TV Program Director's Console showing the Video Switching Control Panel containing the Preview 1, Preview 2, Effects 1, Effects 2 and Program Banks.

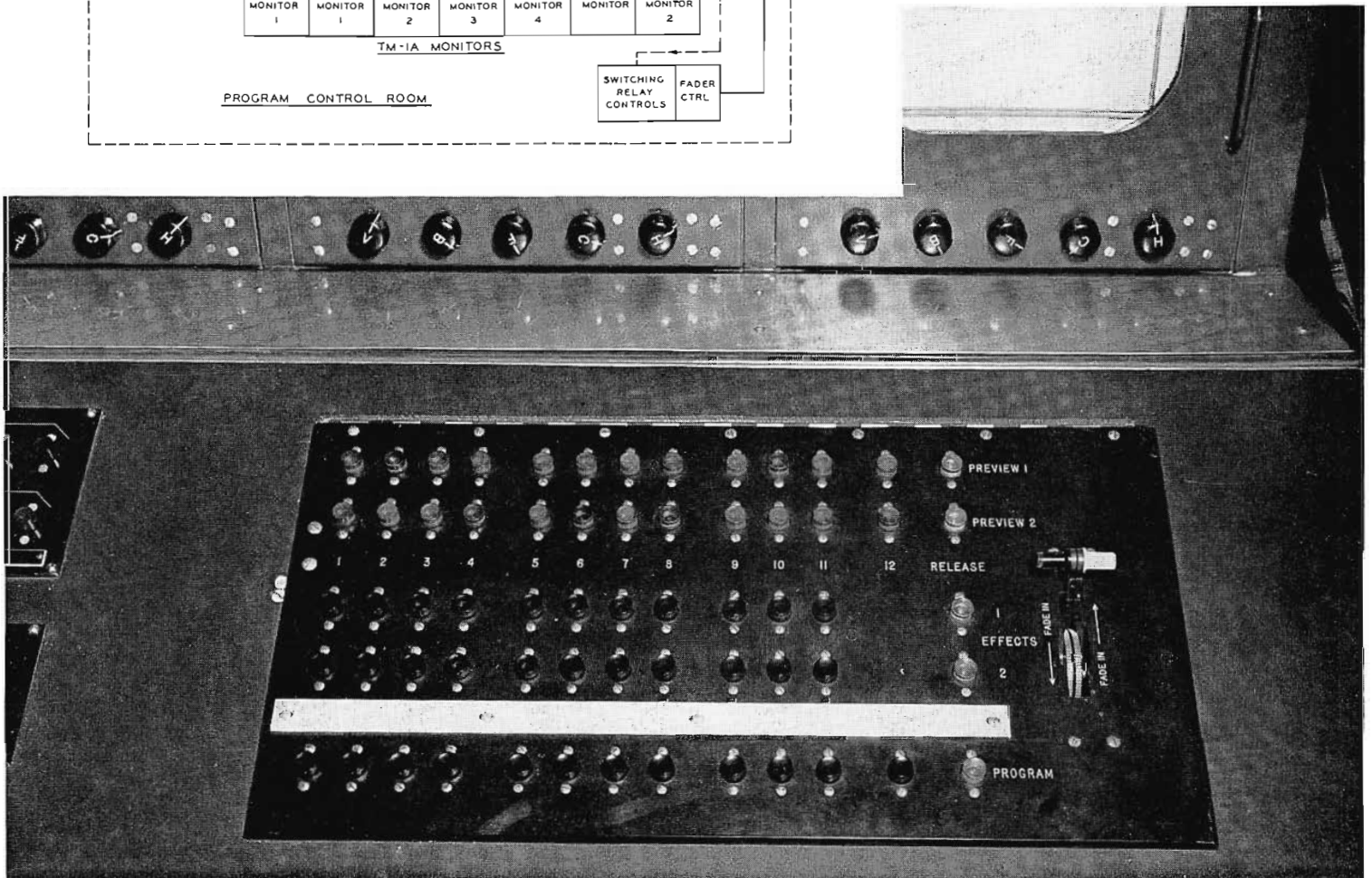



## CONTROL ROOMS "A", "B" and "C" (Cont.)

6. Instantaneous switch between any of the above signals and black.

### B. EFFECTS BANKS 1 AND 2

The output of these two channels are mixed according to the setting of the two fader levers on the right of the switching panel. The resultant mixed output is fed back into the #12 input of the switching system where it can be previewed on either of the two preview monitors and/or switched on the program line.

1. Lap dissolve between any two studio and/or film cameras.

2. Fixed superposition of any two studio or film cameras.

3. Fade down between any studio or film camera and black.

4. Fade up between black and any studio or film camera.

5. Any of the above fades, laps, or superpositions between local cameras and a remote signal when used in conjunction with the "Genlock" in Master Control.

The "Effects" input also provides for the addition at a later date of additional equipment for other special effects, such as horizontal and vertical "wipes", "roll buts", split between two cameras, automatic fades, etc.

### C. PREVIEW 1 AND 2 BANKS

1. Preview monitor may be switched instantaneously to any of the signals set up for this switching system: i.e., local cameras, film cameras, remotes, or "Effects".

In addition to the switching control panel on the programming console, there are located two intercom control panels. One of these is used for the program director's intercom, and the other for the video switcher's intercom. These enable the desk-type talk-back microphones to be switched to the various circuits required for direction of a studio production.

There is also located on the program console a small panel which contains buttons for the remote starting and stopping of any of the film projectors located in the Projection Room. Control is given by the projectionist to the particular studio involved each time a projector is started and stopped. Lights internal in the buttons indicate when this control is available and when the projector is running.

FIG. 15 (below). View of Control Room "C" showing arrangement of technical equipment. Program Director's Console with switching facilities is at left and Audio Console at right.



# FOUR OF THE MANY WOR-TV SWITCHING POSSIBILITIES

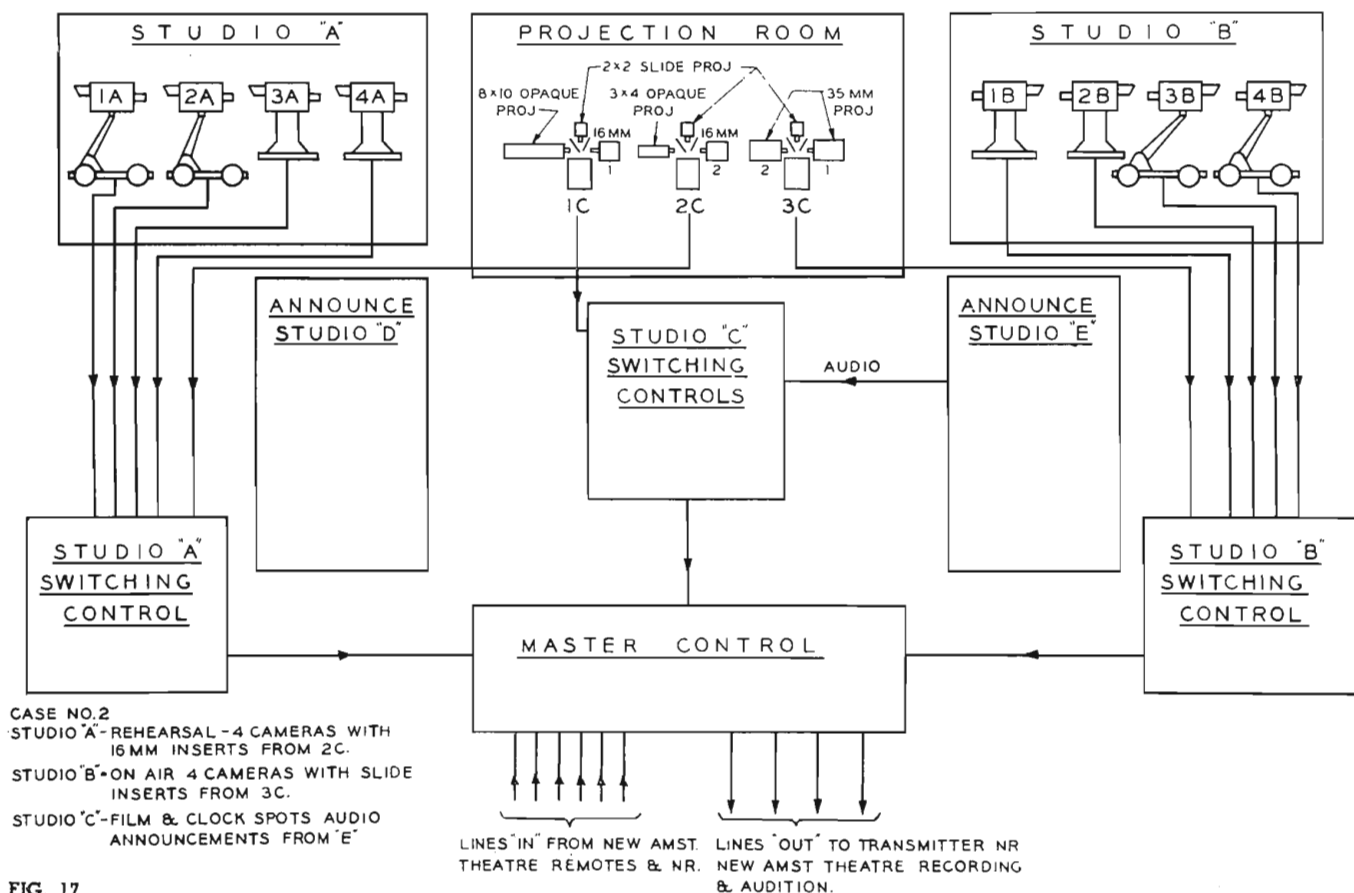
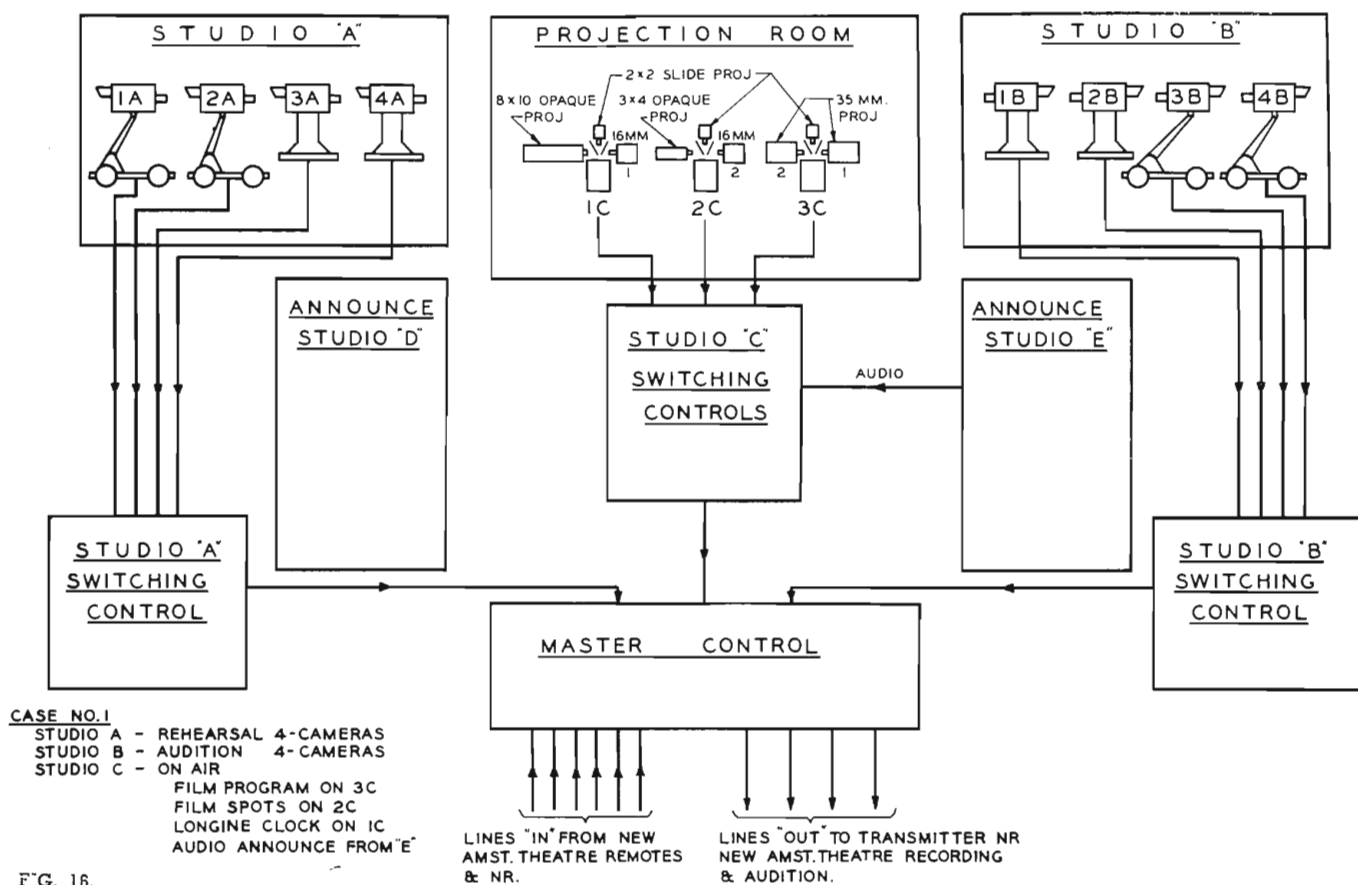

# MADE POSSIBLE BY THE TS-20A SWITCHING SYSTEM

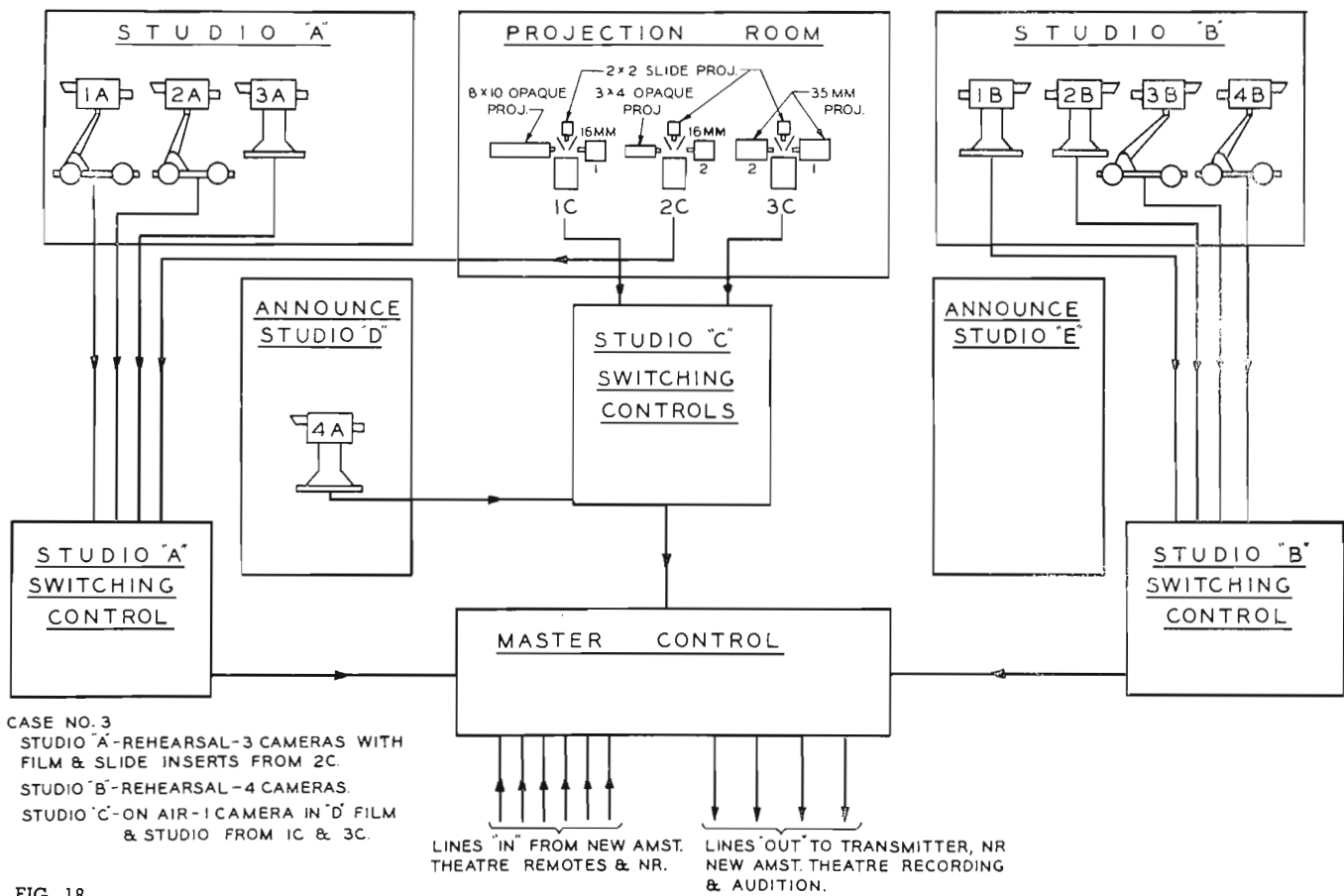

FIG. 18.

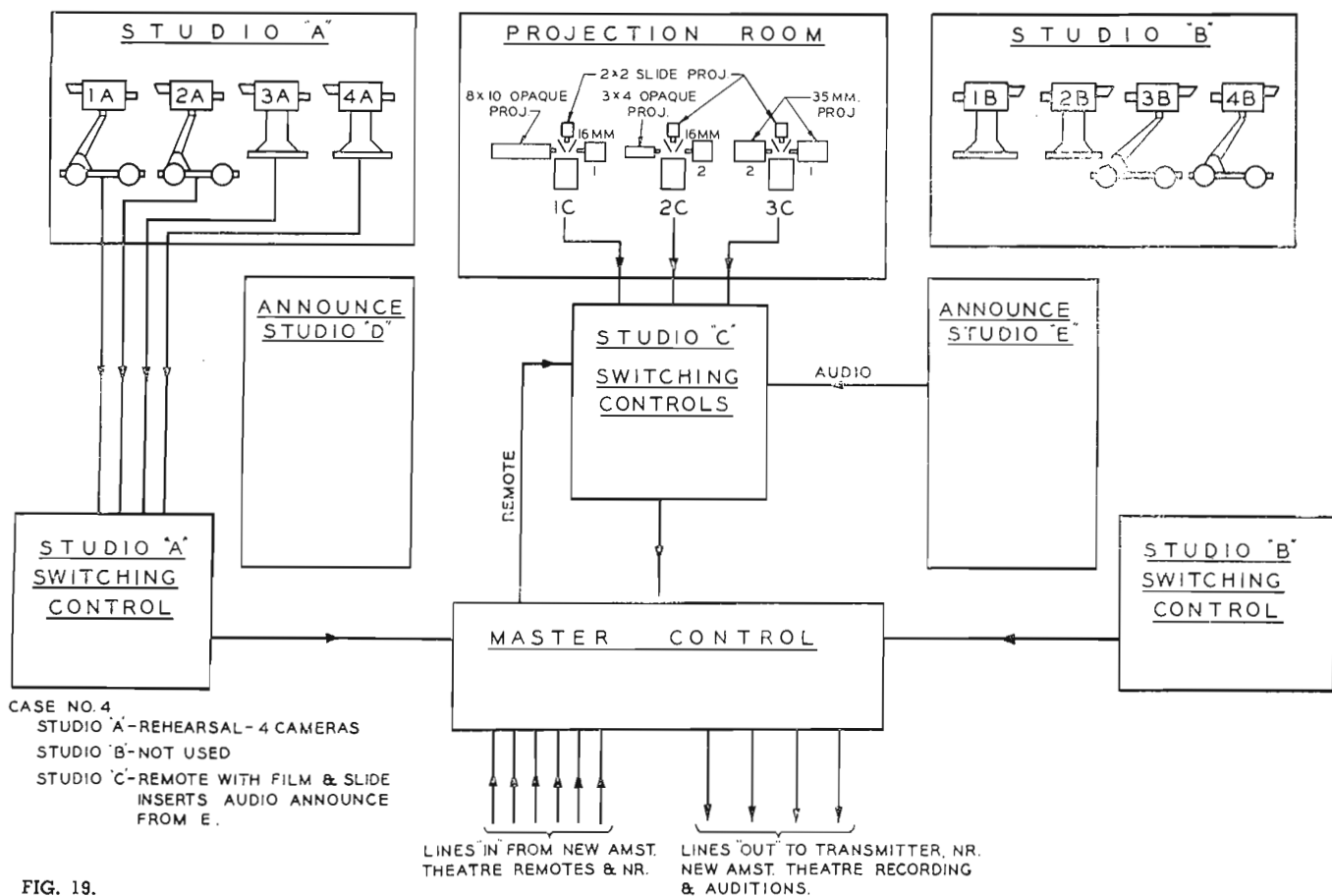

FIG. 19.

## WOR-TV AUDIO CONTROL, ANNOUNCE BOOTHS "D" & "E"

The audio system in each control room is an assembly of standard RCA components. A 76-B4 audio console forms the basic part of the system. This is augmented for additional microphone inputs by two OP-7 mixer amplifiers mounted in a specially built cabinet matching the 76-B. Each of the OP-7 outputs appears on an input fader of the 76-B, thus providing a sub-master gain control on each of two groups of microphones.

In addition, each set of inputs to the OP-7's can be switched to any one of five groups of microphone outlets by means of relays, thus providing for a maximum of forty pre-set microphones about the studio which can be used on different sets as called for. Two microphone outlets in the studio normally used for the boom microphones appear directly on the 76-B fader.

Two turntables and lines from Master Control for film and remotes complete the audio system.

Master Control does all the program output switching and permits audio to be switched with the video or independently. This allows the signal source of the audio to come from a different point than that of the video. Provision is further made for turntable playback over the studio speaker.

Thus, the audio control equipment employed in control rooms A, B, and C provide complete facilities for the handling of microphones, turntables, film sound, and remotes. Remotes are patched to the proper control room in Master Control.

### Announce Booths "D" and "E"

Two announce booths are provided, and each booth is situated so that a view of

the studios is available from them. Each booth may be controlled from two of the three control rooms. This makes a very flexible system in case spot announcements are to be inserted into film or remote programs. It also provides an isolated booth that may be used with the associated studio to allow for the changing of scenes within the studio. Announce booth "E" is about 8 feet by 16 feet, and "D" approximately 10 feet by 20 feet. Either booth can be used in emergencies for a small "one-camera" show if required (see Fig. 21).

The basic equipment and facilities employed in each announce booth are similar, and consist of a TM-1A announce monitor, announce microphones, and required terminations for intercom camera cables and monitoring circuits (see Figs. 22 and 23).



FIG. 20. Partial closeup view in studio "B" control room showing the audio control setup. Facilities consist of an RCA 76-B Console which is supplemented by two RCA OP-7 Mixer Amplifiers.

FIG. 21. When the occasion arises, Announce Studio "D" may be used for a program setup as shown here during an introduction to the "Mystery Rider" film program.

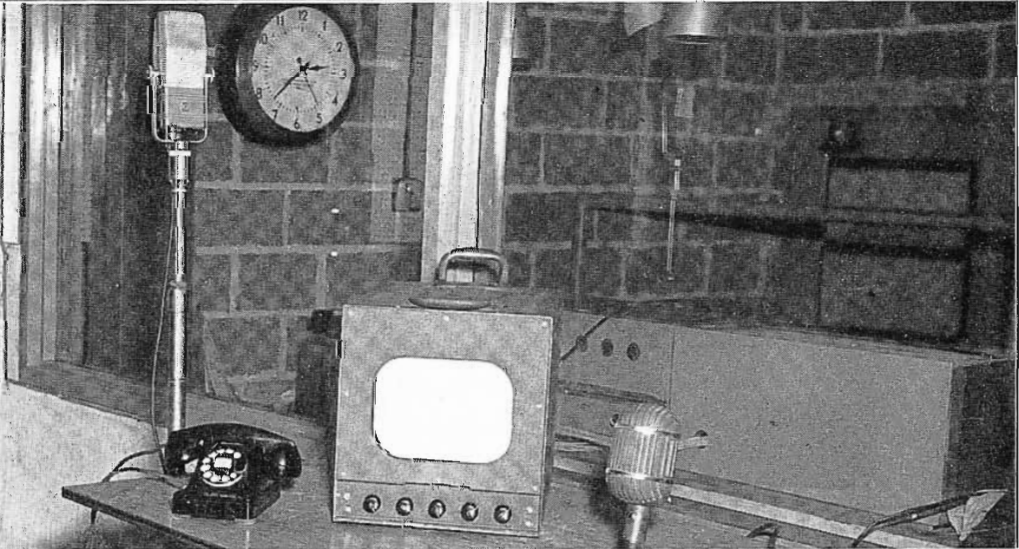
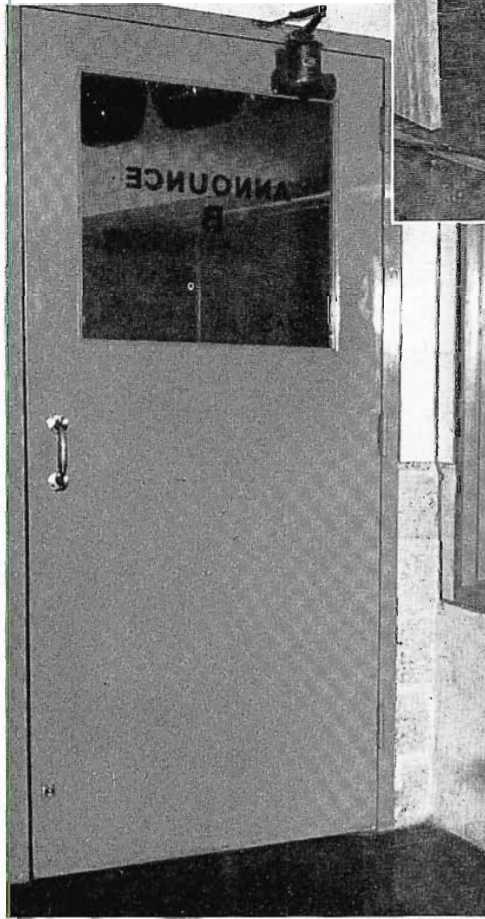
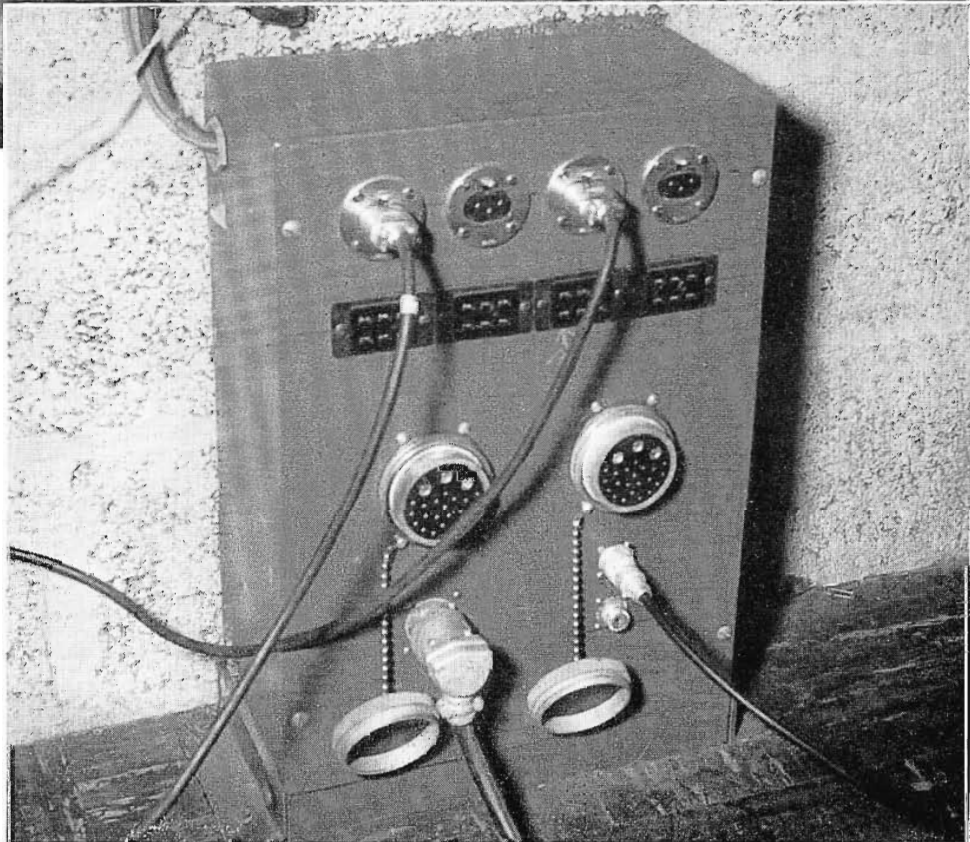

FIG. 22 (above). View of Announce Studio "B" showing left to right, 44-BX Microphone, TM-1A Announcer's Monitor, and announce desk microphone.

FIG. 23 (at right). Closeup of special terminal box located in Announce Studio "E" for microphones, intercom, camera cables, monitor video, monitor power.



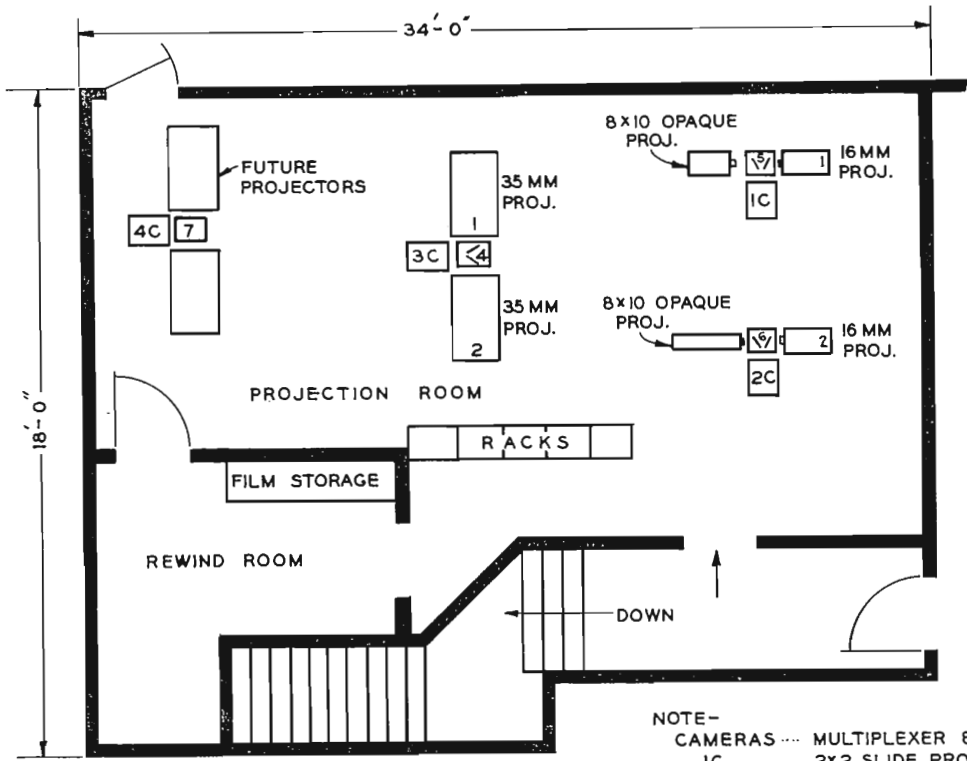

FIG. 24. Floor plan layout of WOR-TV Projection Room facilities located on the second floor.

NOTE-  
 CAMERAS --- MULTIPLEXER &  
 1C 2x2 SLIDE PROJ.  
 2C 4  
 3C 5  
 4C (FUTURE) 6  
 7 (FUTURE) 7

## WOR-TV FILM PROJECTION

The film projection facilities are located on the second floor above the studio control rooms. In this room, which is approximately 18 feet by 34 feet, are located three TK-20A film cameras with space and trench facilities for locating a fourth when required. Each film camera is associated with a film multiplexer for combining optically three sources of film or slides. Two 16mm projectors, two 35mm projectors, one Gray Telop, one opaque projector, and three 2 x 2 slide projectors comprise the projection facilities, distributed as listed below as shown in the sketch of Fig. 24.

### Camera 1-C

16mm Film Projector #1, 8 x 10 Opaque Projector, 2 x 2 Slide Projector.

FIG. 25 (below). View of one end of the Projection Room; the two 35mm projectors and the projection room monitoring racks at left with the TM-1A picture monitors mounted at top.

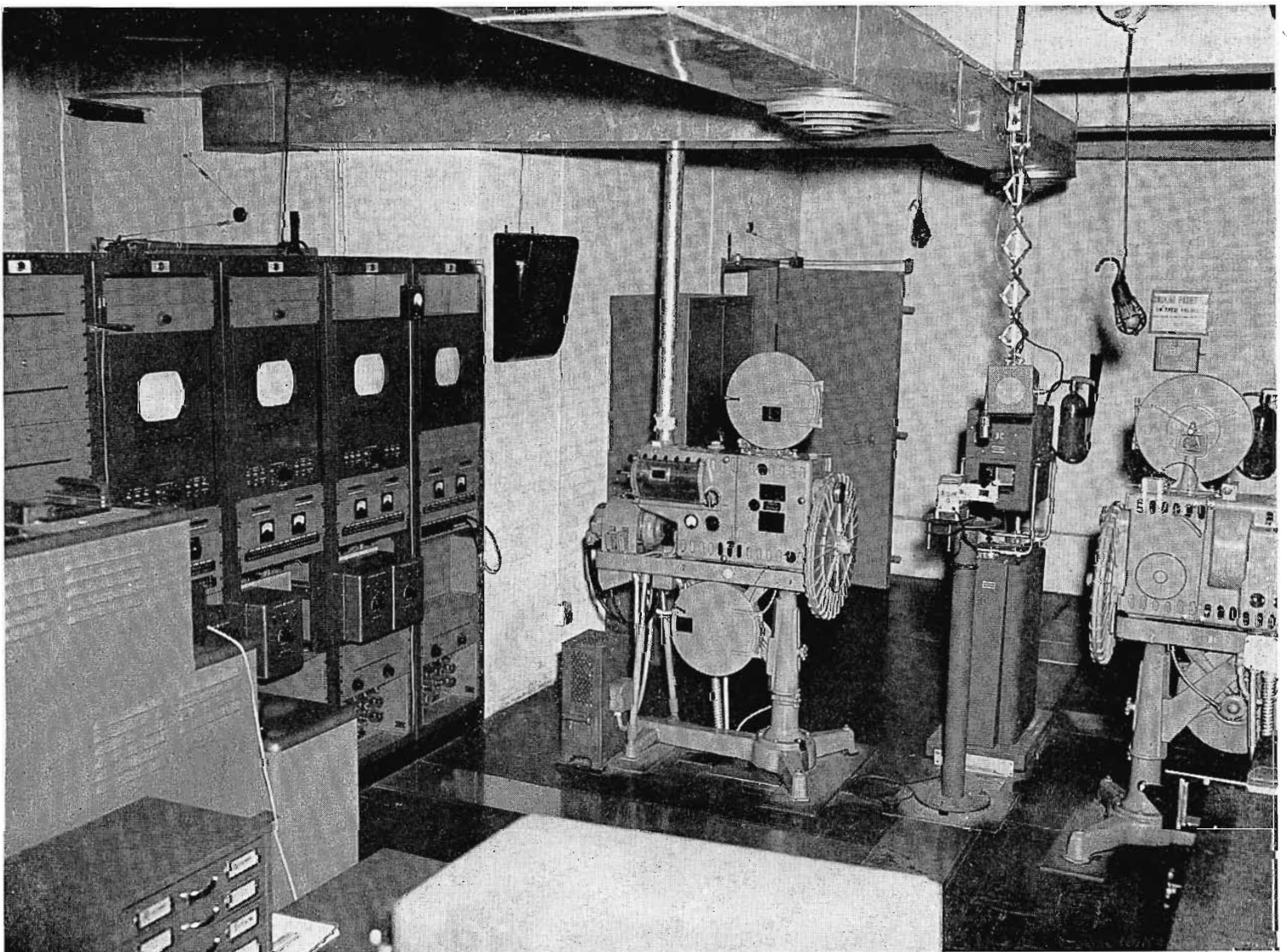

## ROOM (STUDIO "C")

### Camera 2-C

16mm Film Projector #2, 3 x 4 Opaque and Slide Projector and Special Telefax or Scroll Titles, 2 x 2 Slide Projector.

### Camera 3-C

35mm Film Projector #1, 35mm Film Projector #2, 2 x 2 Slide Projector.

Above each film multiplexer, and hung on a sky-hook from the ceiling is a small intercom speaker and talk-back microphone. This is used for direction between the program console and the projectionist. By patching arrangement each of the three projection room intercom assemblies may be set up for communication in any combination with the three program control rooms. Thus, one projector and film camera assembly may be working with Studio A

Control Room for an "On-the-Air" program, while #2 camera chain and projector assembly might be working with Studio B Control Room for an audition. The talk-back microphone on each of the intercom assemblies is opened up by means of a pedal foot switch located near the base of each film multiplexer. In this way the projectionist does not need to use his hands when talking back to a studio control room.

Five racks of equipment are also located in a row along the side of the Projection Room. In these racks are located amplifiers for the projector audio and the intercom systems. Four TM-1A monitors, rack mounted, are also provided for monitoring the output of each film camera chain. A switching panel for each monitor provides for switching the monitor from either the camera output to any of the studio out-

puts, or to transmitter line. Remote control starting, stopping, and dousing circuits are brought over to the racks for centralized control of all projectors. In addition, switches are provided on the racks for each projector, so that remote control may be extended to any of the three studio control rooms or to a remote control panel located in the Camera Control Center. Local starting of any projector is provided at the projector itself by means of a foot pedal switch conveniently located on the floor beside that projector.

Directly off from the Projection Room is located a film rewind and storage room designed for the handling of 35mm nitrate film. Film storage cabinets are provided here with exhausts directly from the cabinets to the outside, in accordance with standard City regulations.

FIG. 26 (below). Another view of Projection Control Room showing location of other equipment. Two RCA TK-20 film cameras with Gray Telop are visible in foreground.

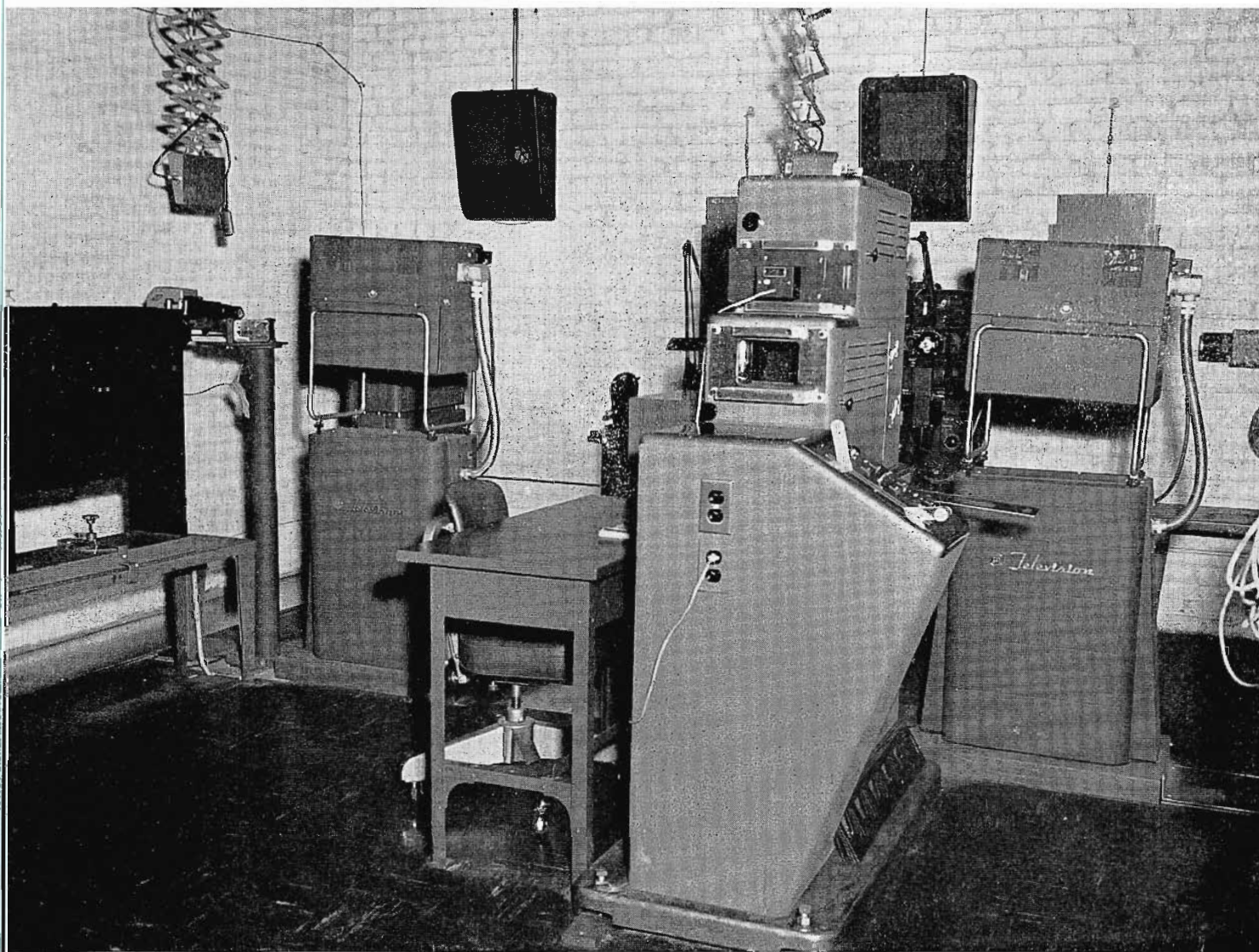

# WOR-TV MASTER CIRCUIT DIAGRAM OF THE VIDEO SYSTEM LAYOUT

## LEGEND

- VDR VERTICAL DRIVING
- HDR HORIZONTAL DRIVING
- BL BLANKING
- DR DRIVING PLUS BLANKING
- S MIXED SYNC
- V VIDEO LESS SYNC
- VS COMPOSITE VIDEO AND SYNC
- DA DISTRIBUTION AMPLIFIER UNIT GAIN
- MA MIXING AMPLIFIER
- SA STABILIZING AMPLIFIER
- C CONTROL CIRCUIT
- 75 OHM PLUG IN TERMINAL
- ✕ SWITCHING RELAY CONTACTS
- ◁ VIDEO JACKS
- NOTE—ALL VIDEO JACKS ARE IN RACKS 5 & 6
- R-1 EQUIPMENT LOCATED IN RACK 1
- U-45 EQUIPMENT DESIGNATED AS UNIT 45  
(See floor plans TD-831 and TD-833. Also see equipment placement within Racks TD-3 788 thru 791)
- CHASSIS TYPE COAXIAL CONNECTOR
- DIRECTION OF SIGNAL FLOW
- CAMERA CABLE CONNECTOR
- ⟷ VIDEO JACKS NORMALLED

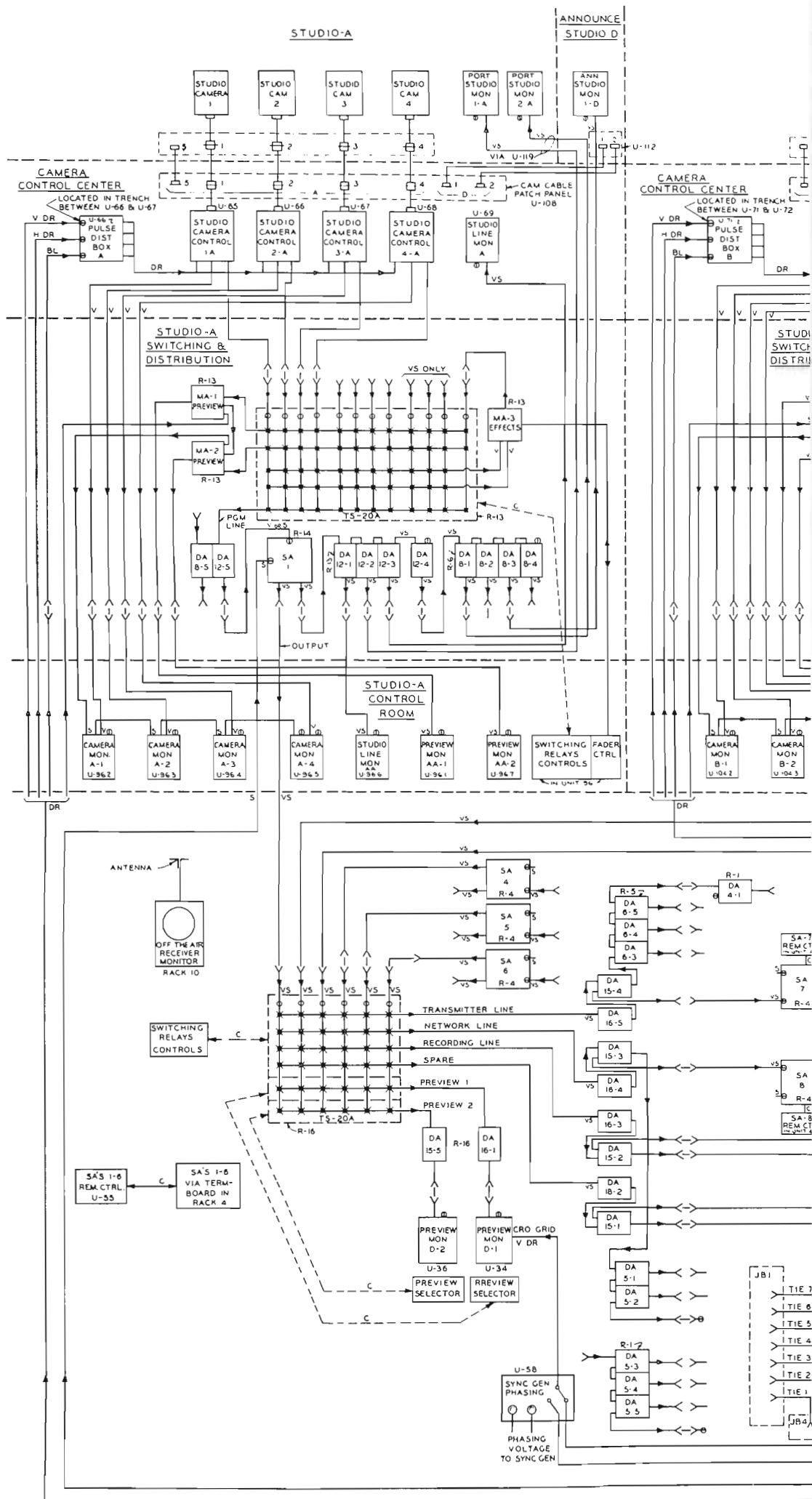



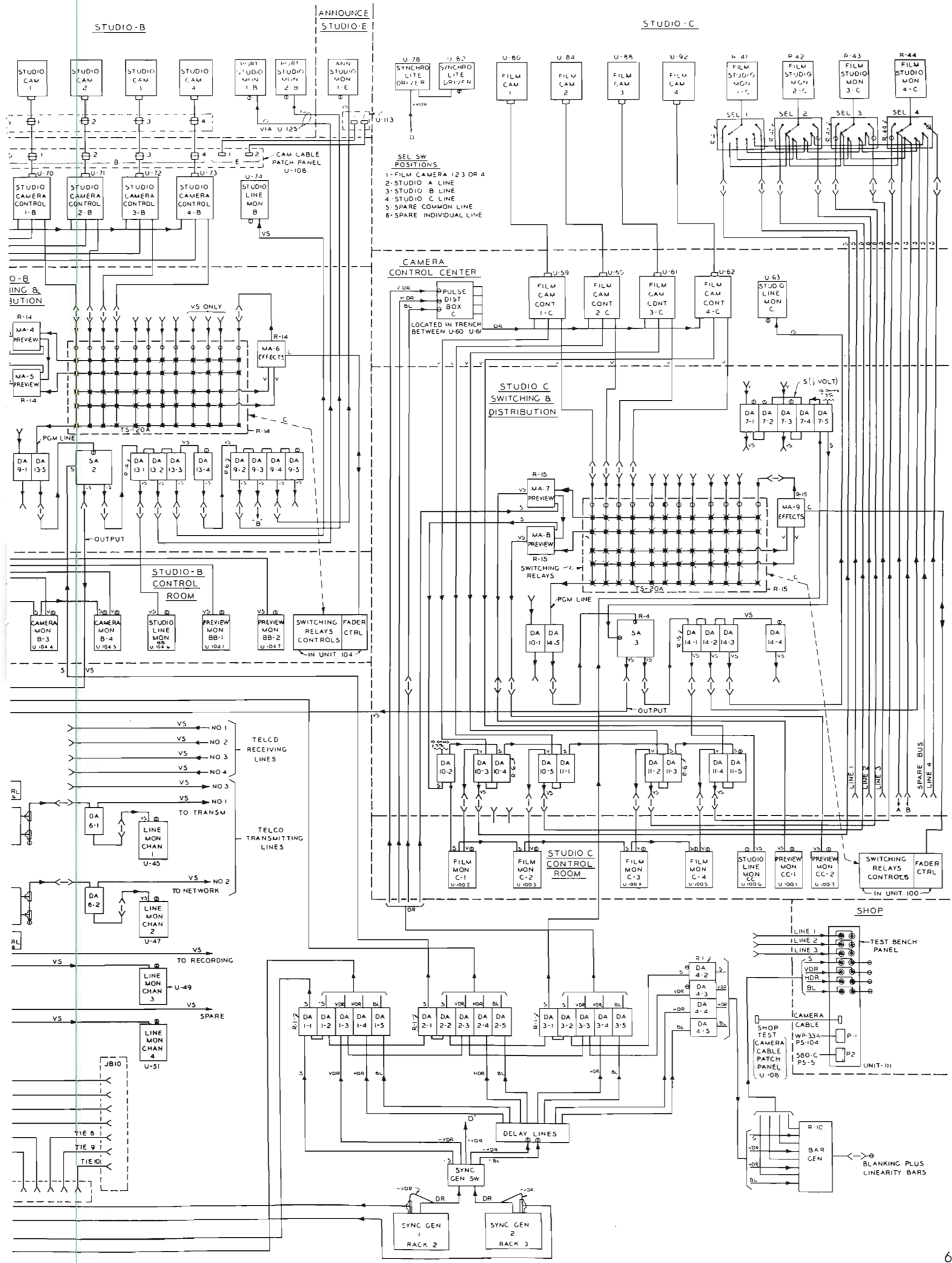



FIG. 28. A special Camera Cable Patching Panel designed by the WOR-TV engineering staff is located in the "Master Control Center."

FIG. 29. The studio camera shading and monitor controls are centrally located in this console. At the extreme left part of the film shading and monitor controls are also visible.

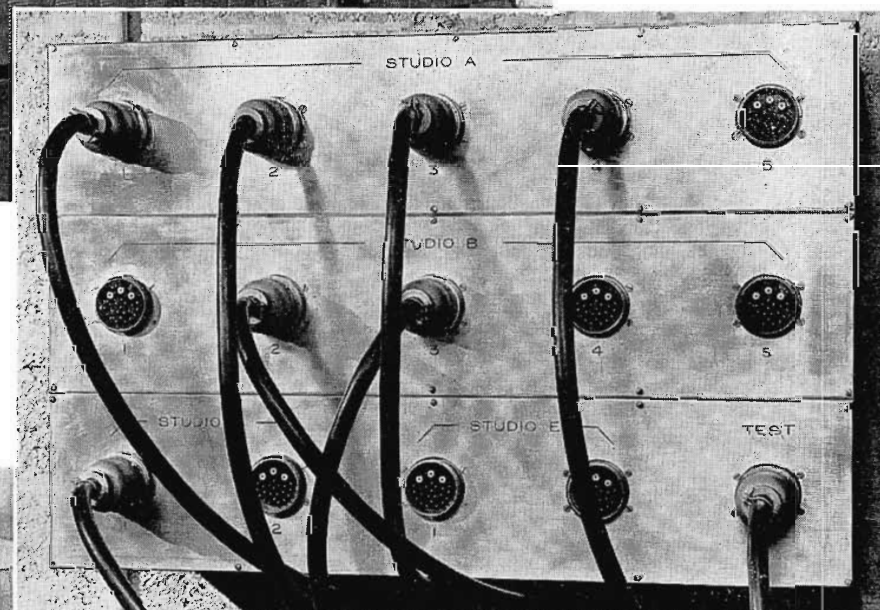

FIG. 27. Center section of the WOR-TV "Camera Control Center" is devoted to film camera controls on right, and master control preview monitors with remote control panels at left. Small windows face the film projection room.



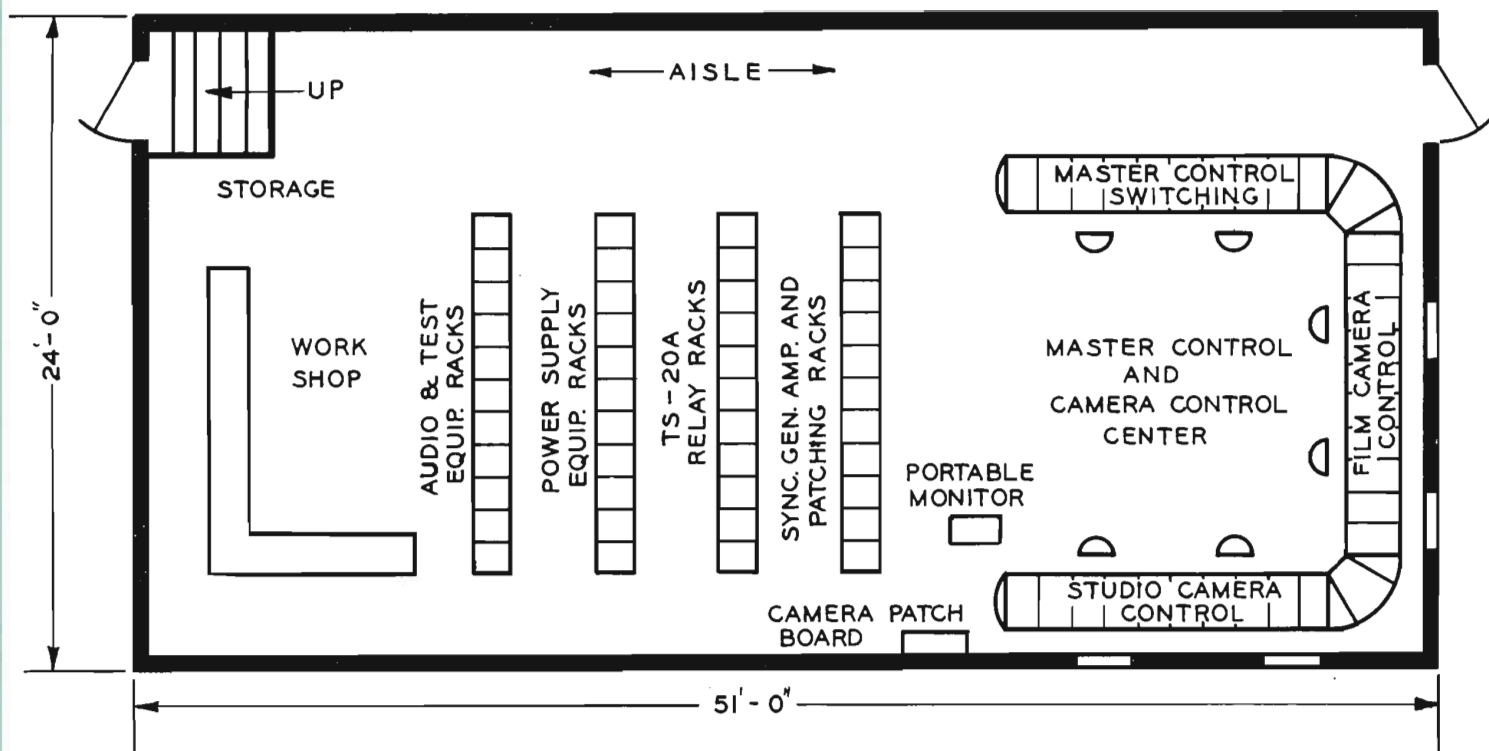

FIG. 30. Floor plan layout of WOR-TV "Master Control" and "Camera Control Center" showing the arrangement of the technical facilities.

## WOR-TV MASTER CONTROL

Adjacent to the film projection room on the second floor is located the combined Camera Control Center and Master Control Room (see sketch of Fig. 30). This is a large room approximately 24 feet by 51 feet. About one-third of this room is taken up by the main operating console space, one-third by the rack equipment, and one-third for a small maintenance shop.

The operating console is a large "U" shaped assembly of standard console sections (MI-26266). The side of the "U" nearest the door contains all of the Master Control switching facilities. The section of the console facing the studios contains all of the studio camera control units. The section facing the Projection Room houses the film camera control units and some master control equipment.

### Camera Control Section

In the Camera Control Center section eight studio camera controls and two line monitors form the section facing the studios. A window into the upper section of each of the two large studios provide visibility for the camera control operators into the studios. This is not considered essential, but it was easy to provide. A

special feature of the Camera Control Center is the camera cable patch panel shown in the photograph. This is mounted on the wall directly adjacent to the camera control units. The sockets mounted on this panel correspond to cables leading to the various studios. Five cables lead to Studio A, five to Studio B, two each to the Announce Studios, D and E, and one to the shop test bench. The camera cable pigtailed that plug into these sockets correspond to the eight studio camera control units. Thus, the eight camera controls can be distributed in any combination among the fifteen circuits to the various studios, depending upon the program requirements for that particular operation. This adds greatly to the flexibility of the over-all system, and enables us to take care of most any special requirement that can arise. It furthermore reduces the total number of camera chains required in such a setup involving several studios. Also, in case of trouble in the equipment during a program or rehearsal, it is very easy to patch in a spare camera control unit so that the equipment in trouble can be released for maintenance. In addition to the patching of the camera control units to any of the studios, it is, of course, necessary to patch the video outputs of the camera controls on the jack panels to the

corresponding program control room where the switching is to be done.

Besides patching the video outputs of the camera controls to the particular switching systems involved, it is, of course, important that tally circuit information and intercom facilities for that camera and camera control follow the particular companion program console. For this purpose a special tally and intercom patch panel is provided directly above the video patching panels. Here, a three-circuit plug for each of the studio and film camera chains is provided with jacks corresponding to the inputs on each of the three control room switching systems so that any camera control can be set up on any input to any of the three switching systems for tally and intercom control.

At each section on the camera control console is mounted an intercom box and jack. This is tied in with the corresponding camera intercom system. Thus, a camera control operator may plug in a headset at one of the sections he is working with and have complete two-way intercom with the video switcher down in the program control room that he is assigned to and also with the cameraman. In addition, on a separate earphone he may listen to the program audio from that studio.

(Continued on page 67)



FIG. 31. Front view of the WOR-TV Master Control Switching Console which consists of facilities for switching six incoming circuits to four outgoing channels.

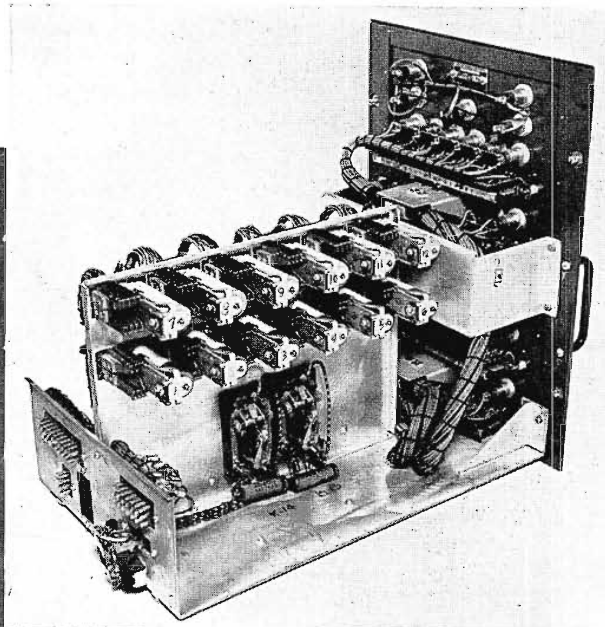

FIG. 32. View of one of the switching panels removed from console to show the construction and arrangement of the switching relays.

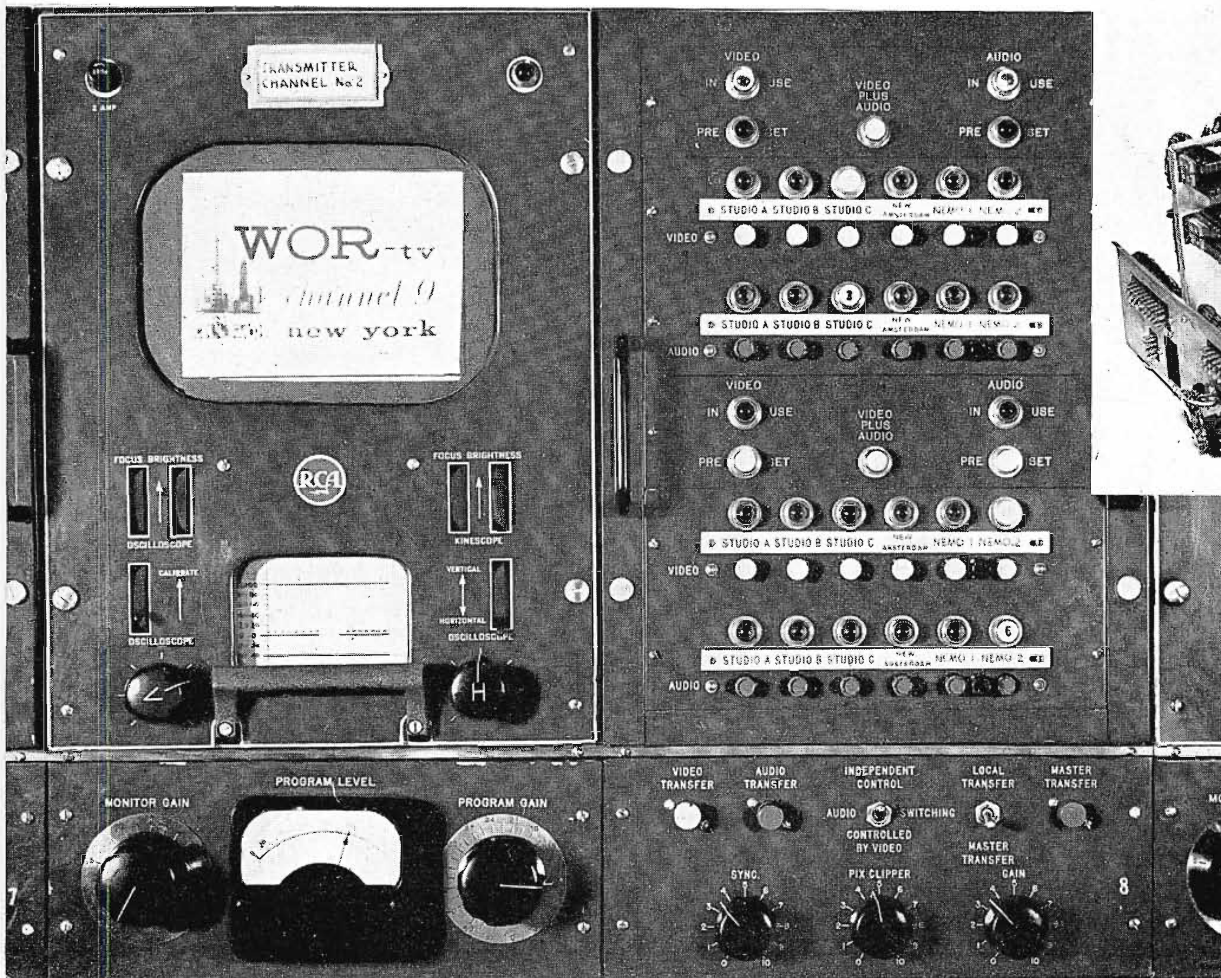

FIG. 33. Closeup of one of the WOR-TV Master Switching panels showing panel arrangement of controls, tally lights and push buttons associated with one channel.

## WOR-TV MASTER CONTROL (Continued)

The master control switching comprises facilities for switching six incoming channels to four outgoing circuits. This is set up for a pre-set system with provision for either independent audio-video switching or simultaneous audio-video switching as required. All four outgoing channels may be tripped by a single master button, or any group can be switched together, leaving out other channels. A picture monitor, TM-5A is associated with each outgoing channel in addition to an audio monitor and VU meter. Controls on each outgoing channel provide for the setting of video and audio levels independently.

### Master Switching (Thru TS-20A Relays)

Master switching is facilitated by the use of the TS-20A video relay system which frees control equipment and switching from usual operating restrictions. For example, the relays are controlled by simple d-c lines from any desired point. Thus, push-button control panels are conveniently located for the operator, with relays and associated equipment "rack-mounted," as desired (see rack equipment on following pages).

The actual switching control panel on each outgoing channel is mounted in a standard console housing section which is

made up as a unit with the audio switching mounted on a chassis behind the panel (see Fig. 32). In cases where simultaneous audio-video switching is done, the switching is controlled by the video switching relays, which in turn drive the audio switching relays from the tally contacts on the video relays. The push buttons used for pre-setting and switching control are made up of a standard RCA push-button switching assembly mounted on an adapter panel. The whole system comprises eight of the standard console sections in width, and makes a very flexible master control switching system. Only composite video signals are handled here, such as the studio outputs, theatre, and remotes, so that no fading or lap dissolving is done. Switches are made only at the end of a complete show which comes from one of the studios.

### Monitoring and Other Facilities

Two TM-5A Master Monitors located in the console section to the right of the master control switching console are used as preview monitors for master control switching. Each of these monitors can be switched to any of the six inputs to the master control switching for checking levels and matching the outputs of the several studios and remotes before they are actually switched to the outgoing lines. These

monitors are fed from two additional banks on the master control relays (TS-20A). In between these two TM-5A preview monitors are located remote controls on six stabilizing amplifiers. These are the stabilizing amplifiers that are used to feed the normal inputs to the master control switching system. Therefore, at this one point it is possible to adjust the synchronizing and picture levels on each of the studio outputs and all the remotes to the standard level while watching the oscilloscope on the TM-5A. It is also possible at this point to check the phase of the vertical synchronizing pulse on a remote coming in with that of the local sync generator. This is done by using the vertical driving pulse from the local sync generators as a negative blanking pulse on the grid of the cathode ray oscilloscope in the preview monitor.

An adjacent console section houses remote controls on the synchronizing generators. This consists of a remote control sync generator switch, enabling a standby sync generator to be switched in at this point. In addition, two 60 cycle selsyns provide a continuously variable phase for the 60 cycle lock-in on each synchronizing generator. A TG-45A Genlock unit has been installed which enables the local sync generators to be phased with a remote incoming signal line-by-line, as well as field-by-field.

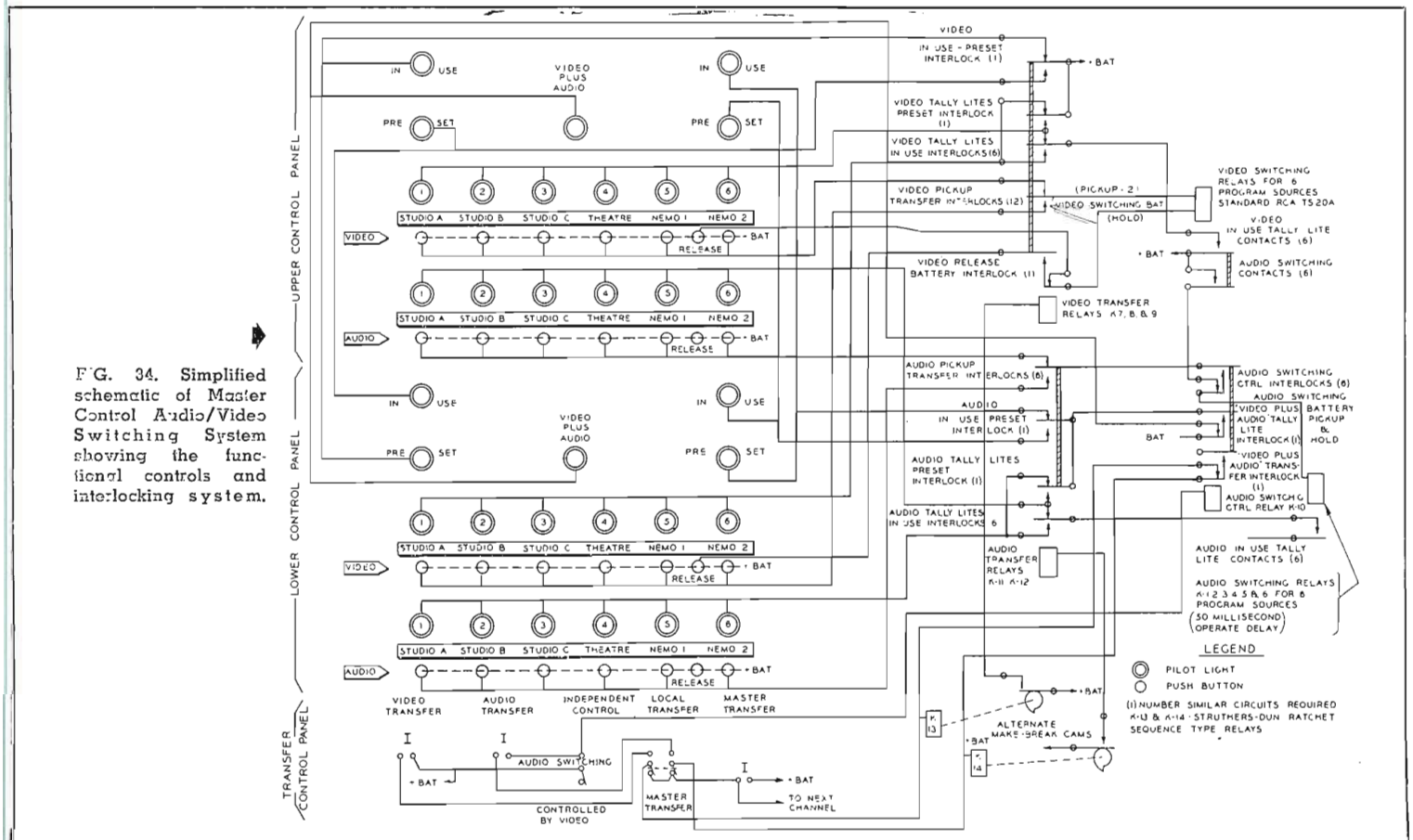

FIG. 34. Simplified schematic of Master Control Audio/Video Switching System showing the functional controls and interlocking system.

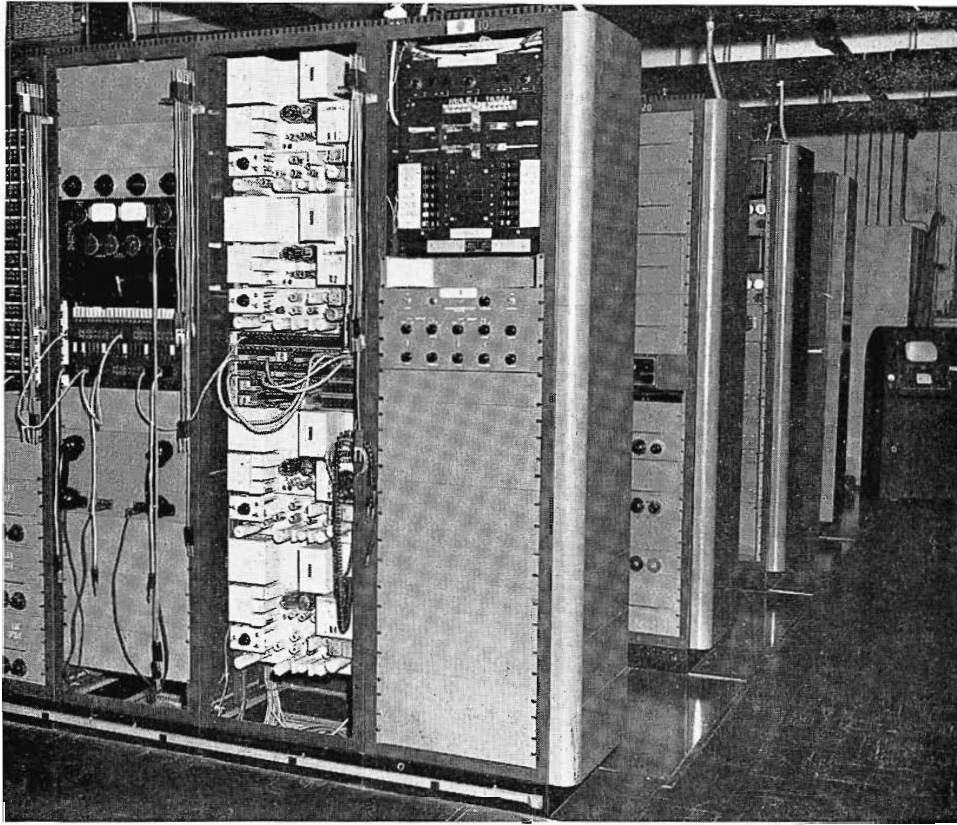
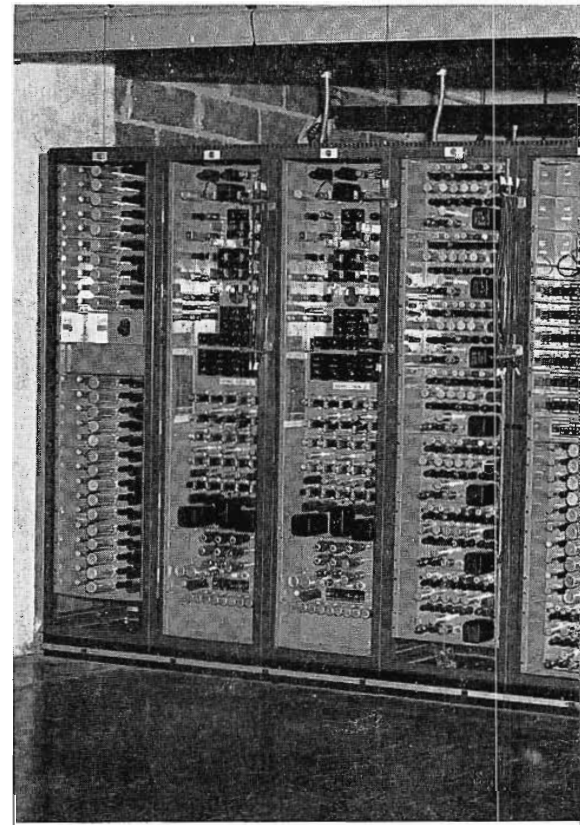

FIG. 35. View of the overall lineup of WOR-TV Master Control Equipment Racks. Complete arrangements consist of four rows of ten racks each.



## WOR-TV MASTER CONTROL EQUIPMENT RACKS

A total of forty equipment racks divided into four rows house all of the power supplies, amplifiers, synchronizing generators, switching relays, patching facilities and telephone company equipment for the whole plant. The first row of equipment racks is devoted to sync generators, audio/video patching, stabilizing amplifiers and distribution amplifiers.

In the second row of racks are located the TS-20A video switching relays. A separate rack is assigned to each of the studio switching systems and to the master control switching system. Besides the relays, each rack contains the mixer amplifiers used for fader application and for the preview monitor sync mixing, and, in addition, the distribution amplifiers associated with each studio switching system. Other racks in this row contain the audio amplifiers associated with the master control switching.

The last two rows of racks contain mainly power supplies. Approximately 150 power supplies are mounted here to provide power for all monitors, amplifiers, and camera chains in the plant. All a-c power distribution to the rack equipment is carried by means of 4 x 4 overhead ducts from the main circuit breaker distribution

panel located on the wall in the Master Control Room. "Greenfield" is used to bring the a-c power down from the overhead duct into each rack where required. Within the rack the a-c power is distributed through a 2 x 2 duct having pigtailed branching out at the appropriate points with motor connectors to plug into the power supplies.

All d-c circuits and signal circuits are fed out through the bottom of each rack through trenches in the floor to the appropriate equipment. All WP-33B and 580-C power supplies were slightly modified to allow 115 volts a-c to be brought out on the Jones connector as well as the d-c circuits. Thus, only a single multiwire cable is required to take the complete power from the Jones connector on the power supply to the monitor in its console. This eliminates the need for any junction point at an intermediate terminal strip. The whole installation was therefore considerably simplified. A .020 inch copper grounding strip 10 inches wide passes through all trenches and each rack and console housing is tied into this grounding strip, which in turn is carried to the building ground. All external circuits to and from Master Control are handled by tele-

phone lines. About twenty-four lines are used for this purpose. These are routed to and from various points in the city, such as remote pickup points, theatre studio, and two outgoing lines.

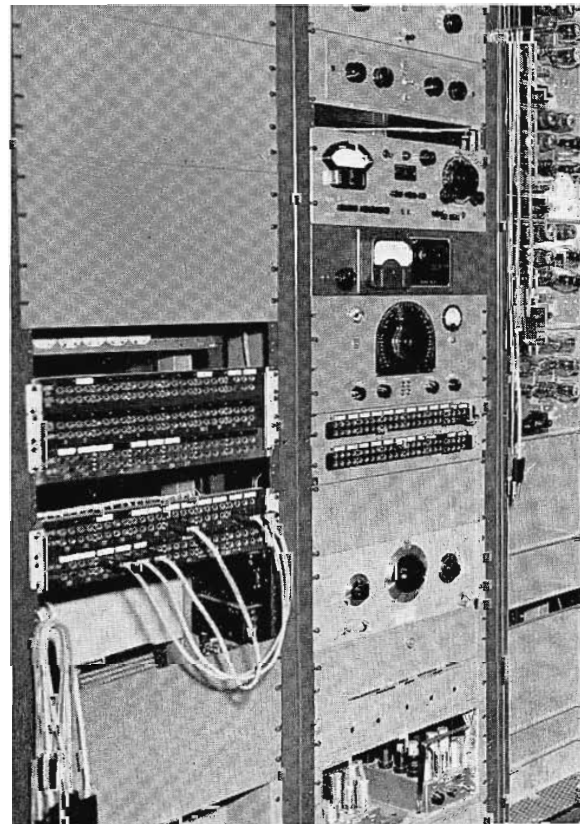

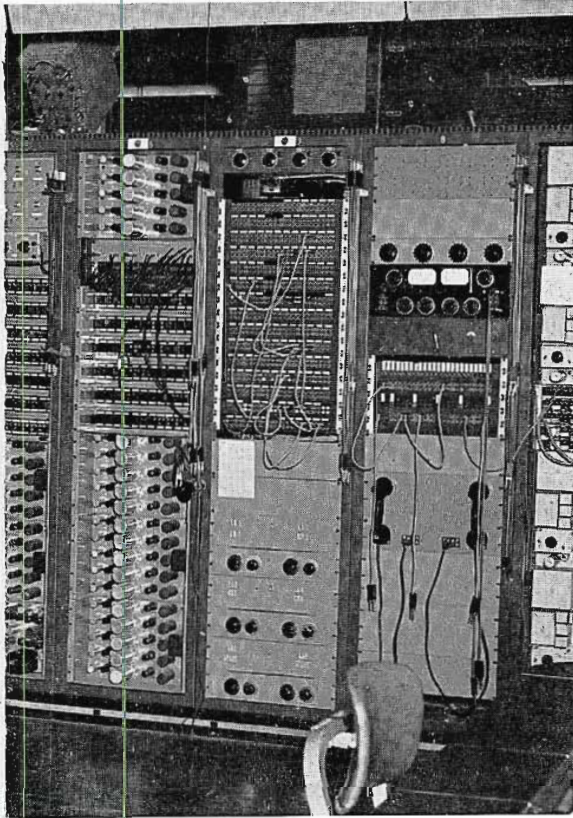

FIG. 36 (above). First row of Master Control Racks containing synchronizing generators, audio-video patching, "TelCo" equipment, and amplifiers.

FIG. 39 (below). Fourth row of Master Control Racks which include the audio test equipment and additional power supply equipment.

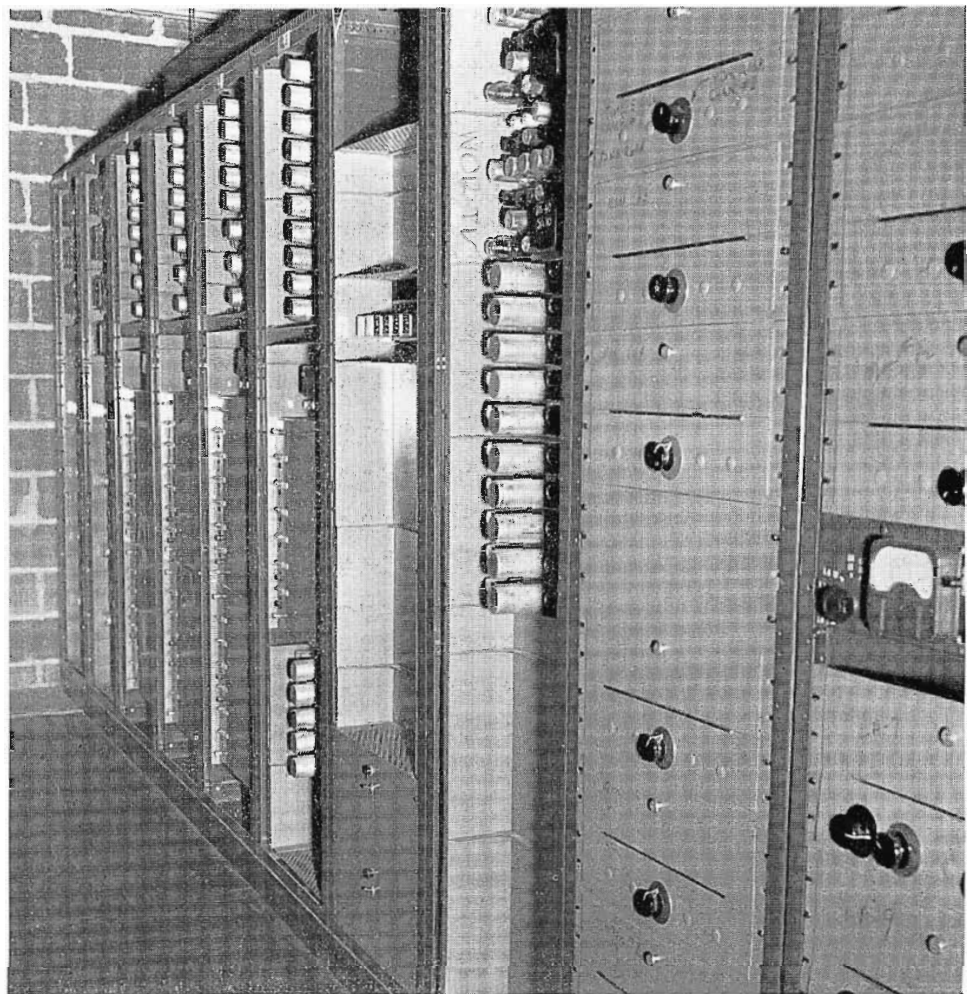
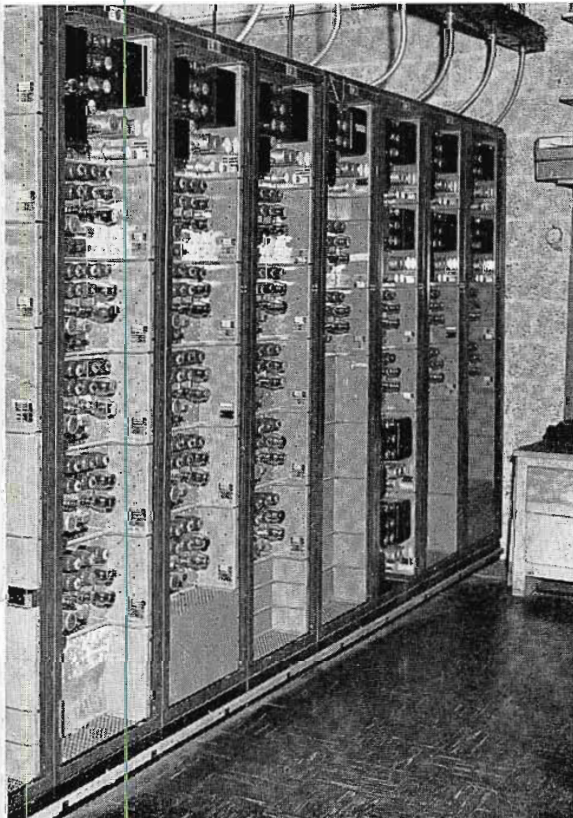

FIG. 37 (above). Second row of Master Control Racks which house TS-20A Video Switching Relays—one rack assigned to each studio system.

FIG. 38 (below). Third row of Master Control Racks showing centralized power supplies for monitors, amplifiers and WOR-TV camera chains.

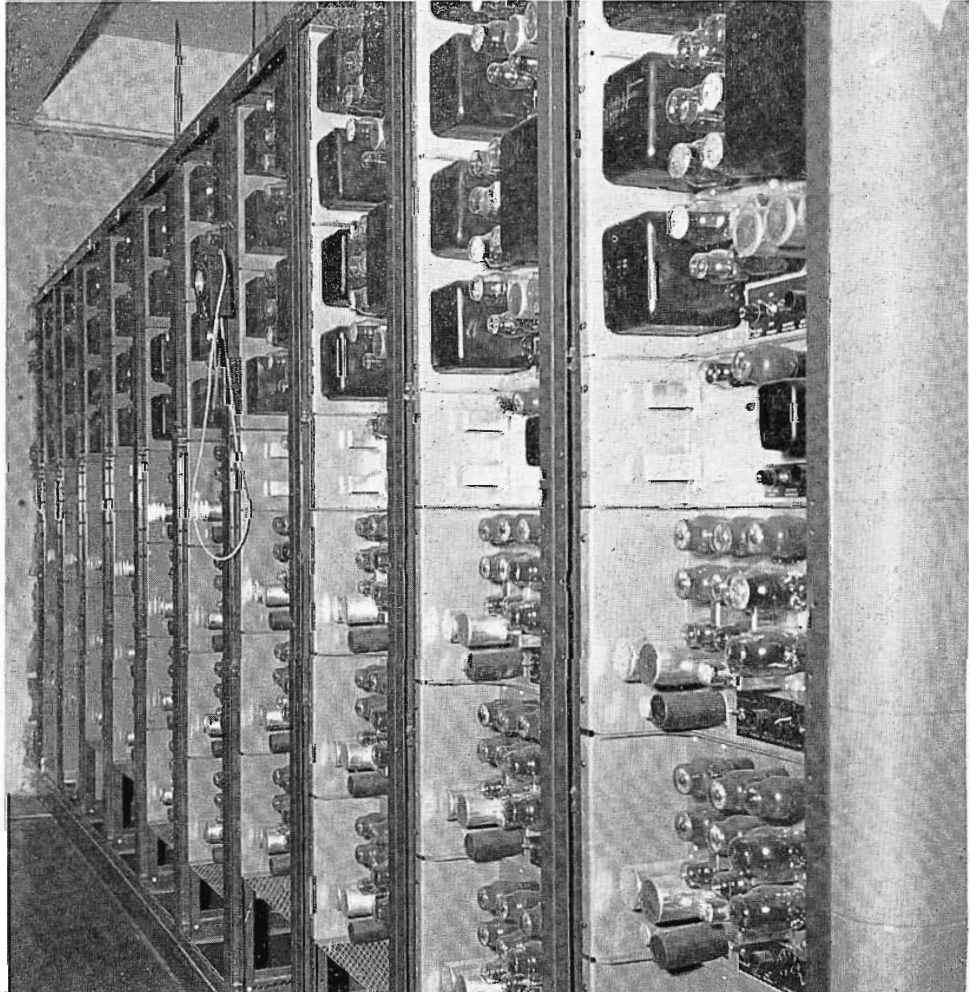



FIG. 40. Closeup of stage at New Amsterdam Theatre showing the handling of cameras and microphones during actual program scene.

FIG. 41. Overall view of the New Amsterdam Theatre studio showing the studio facilities available. Three television cameras and two mike booms are visible on the respective ramps. At center ramp, a studio camera is mounted on a two-man dolly.





## WOR-TV NEW AMSTERDAM THEATRE - STUDIO

In addition to studio facilities at 67th Street, WOR-TV has equipped the New Amsterdam Roof Theatre for television. In fact, it was from this theatre that WOR-TV first went on the air with television programs, and for four months this was where all studio and master control facilities were operated.

This theatre has had a long history in both theatrical performances and radio, but had been vacant for several years prior to WOR acquiring the use of it. Located in Times Square, it has many advantages from the point of view of accessibility. A stage 40 feet by 44 feet provides adequate floor space for television programming, and a seating capacity of 450 provides an ample audience. To convert the existing theatre for television presented considerable difficulties. A steel apron was built out over the orchestra pit to extend the working area of the stage. In addition, three camera ramps at stage level were built out radially from the two sides and center of the stage. This, of course, necessitated removing some of the orchestra seats.

A control room was hurriedly constructed and located in an old storage room directly beneath the orchestra. This,

of course, provides no vision from the control room to the acting area and there was some question as to how well this arrangement might work out in practice. Experience in operating from this control room over a period of a year has indicated that there has been no great disadvantage from this blind operation.

### Control Room Equipment

The technical facilities at the New Amsterdam Theatre include three TK-10A studio camera chains with a TS-10A switching system. In addition, a TK-20A film camera chain is used with a 16mm film projector and 2 x 2 slide projector. All of these control units are located together to form one operating console in the control room. An additional TM-5A monitor is used in the console for a preview monitor for previewing incoming remotes or signals sent back from 67th Street Master Control. This preview monitor is switched by one bank on the TS-1A switching panel located directly on the right side of the console.

On a slightly raised platform to the rear of this console is located the audio operator's console, which is a modified 76-B

assembly similar to that used in the 67th Street studio control rooms. The program director in this case also operates from the raised platform beside the audio operator where he has intercom facilities for communicating with the cameramen and stage manager. An on-the-air monitor receiver is located on a shelf directly above the operator's console. To the right of the operating console is located a row of fourteen equipment racks. These contain all of the power supplies, distribution and stabilizing amplifiers, and two TG-1A synchronizing generators as required for the operation. The projection facilities are located directly in front of the console in the same room. Here a bad building vibration problem forced the construction of a shock-mounted platform on which is mounted the film camera, the film projector, and the multiplexer.

6 x 6 ducts from the control room to the stage carry all camera cables and monitor cables. An extension of this duct to the balcony permits the use of additional cameras in the balcony when required. On stage two cameras are mounted on tripod dollies with the center camera mounted on a crane-type dolly. Two Mole-Richardson microphone booms are used on either side of the stage.

FIG. 42. View of the Program Control Room at the New Amsterdam Theatre. The video console is at a level lower than that of audio console. Sync Generators, Stabilizing Amplifiers and associated equipments are located at the right in fourteen equipment racks.

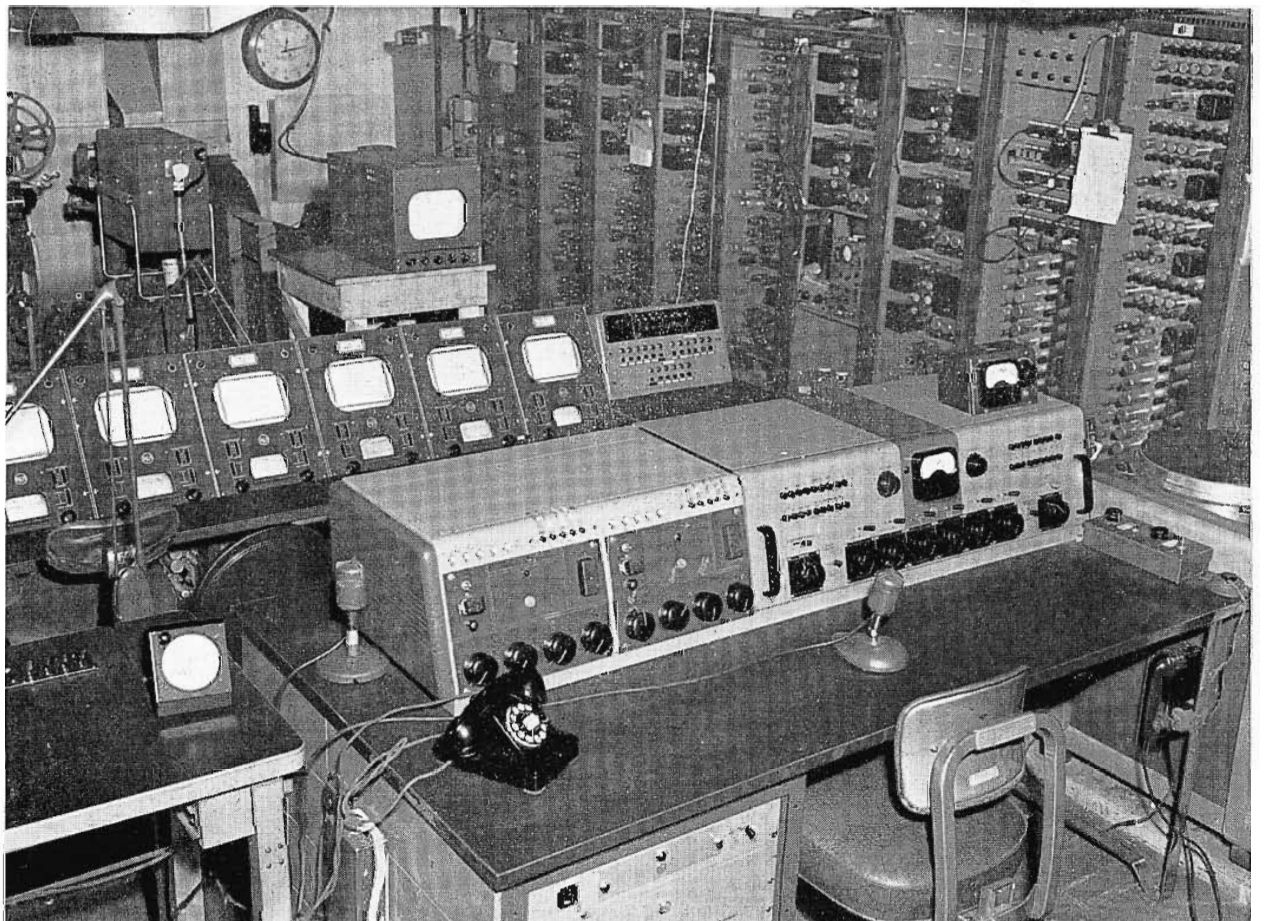

## WOR-TV REMOTE PICKUP EQUIPMENT

### Field Equipment

A total of eleven cameras are used for remote pickup work. One three-camera chain is permanently kept with a specially built mobile unit. This equipment is always operated with the control units in the truck and the cameras taken into the pickup point by extending the camera cables. The other field cameras are normally transported by another truck to the desired remote location where they are taken out and the control units set up inside near the point of pickup. Normally, all of these remote programs are sent back to the Master Control by means of Telephone Company video lines. However, two 7000 megacycle microwave units are available when required to augment the Telephone Company facilities.

WOR-TV's biggest remote pickup to date has been the televising of the Brooklyn Dodgers' games from Ebbets Field this year. First, studies were made through the use of movie cameras at Ebbets Field during the past winter and spring, and through the runoff of these films decisions were made on camera placements. Seven camera chains are permanently installed for the season in a control room built into a room in the grandstands. For this pickup four cameras are used continuously on the game, one with a Zoomar lens. A fifth camera mounted on a studio type pedestal is used in a commercial studio for Schaeffer, located adjacent to the control room. Two

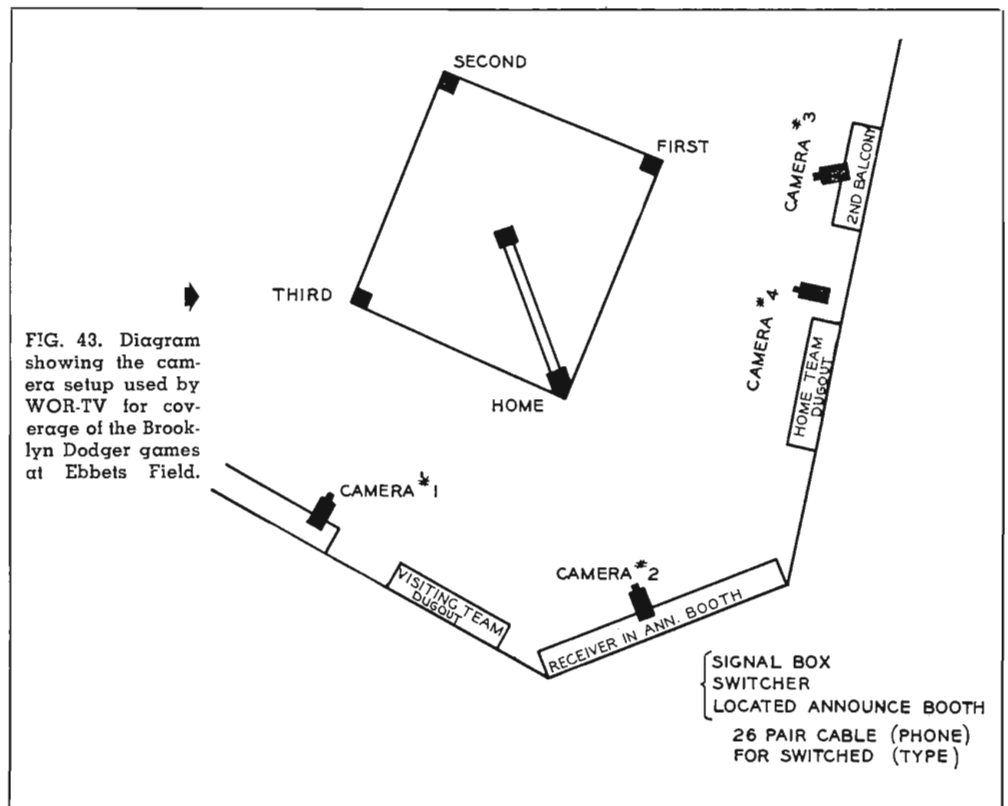

other cameras are used in a second commercial studio for the Bob Edge program, which follows after each game.

The Dodger telecasts from Ebbets Field, which are carried exclusively on WOR-TV, Channel 9, are handled by a 21-man team composed of two 10-man crews and the Field supervisor. One of the crews covers daytime games and the other, night games. Each has a video shader, an audio engineer and seven cameramen, including a re-

lief man. With each of the field units mentioned above, the auxiliary field switching unit is used to allow lap dissolving and super-position of cameras. Two synchronizing generators are normally carried with each set of field equipment with a specially built switch for substitution of the standby generator in case of trouble.

### Conclusion

In general, the facilities at WOR-TV so far have proved adequate to produce almost any type of production which has been requested. Its flexibility and the convenience of its studio arrangement help greatly in producing television shows. The system of utilizing a single camera control center for several studios has worked out very well, and adds considerably to the flexibility of the system. Such a system could be easily extended to more studios, although there probably would be a practical limit as to the number of studios which could easily be handled together with one camera control center. However, at least five or six studios could be handled easily in this manner.



FIG. 44. "Johnny-on-the-Spot," WOR-TV's Mobile Unit is equipped with three field cameras, microwave transmitter, camera control units, video picture monitors, and camera switching equipment. In addition, the unit houses a radio telephone and AM broadcasting equipment.

FIG. 45. Red Barber, commentator on the Dodger games for WOR-TV's coverage from Ebbets Field, is shown near the inter-communication "Signal Box" used to communicate with the camera director in the control room. The special system was designed by WOR-TV's Sports Production Manager Roy Meredith at suggestion of Barber.



FIG. 46. View of the WOR-TV control room located under the stands at Ebbets Field. WOR-TV camera director Ralph Giffen is at the right.



RCA Studio Cameras at WOR-TV, New York  
WOR-TV uses 11 cameras like these—  
6 mounted on RCA Studio Pedestals and  
5 mounted on RCA Crane-type Dollies.

# America's Leading Stations Use RCA TV Equipment

... **WOR-TV, for instance**

ONE OF THE NEWEST and most carefully planned television stations in the East, this great Mutual Network Station is now delivering video shows to more than 1,500,000 homes in the New York metropolitan area.

Widely known for excellence of its technical facilities, WOR-TV is backed by one of the most able engineering staffs in the business. Not satisfied to recommend studio and field equipment from specifications alone, *this staff carefully tested and compared the equipment of several manufacturers.*

Today WOR-TV is supported by a complete installation of RCA TV Studio Equipment. Eleven studio cameras like those pictured here. Eight RCA Field Cameras—that help give New York the widest sports coverage in television. A complete RCA push-button video relay-switching system to serve the master control room and three studio control rooms. Complete RCA film camera chains . . . picture monitors . . . stabilizing amplifiers . . . synchronizing generators . . . distribution amplifiers . . . power supplies.

When you plan for TV . . . or add equipment to your set-up . . . follow the networks. Go RCA!

Your RCA TV Equipment Sales Engineer will help you plan. Call him. Or write Dept. 19-GD, RCA Engineering Products, Camden, N. J.



TELEVISION BROADCAST EQUIPMENT  
**RADIO CORPORATION of AMERICA**  
ENGINEERING PRODUCTS DEPARTMENT, CAMDEN, N. J.

In Canada: RCA VICTOR Company Limited, Montreal

**RCA Field-Intensity Meter**  
**Type WX-1A**  
**50 to 220 Mc**



**NEW** *field-intensity meter*

**—for the television and FM bands**

**SPECIFICATIONS**

- Freq. Range . . . . . 50 to 220 Mc
- Sensitivity . . . . . 5 microvolts to 20 microvolts/meter, depending on frequency
- I-F Bandwidth . . . . . 150 kc
- FM Adjacent Channel Selectivity . . . . . 65 to 1
- FM Band Image Ratio . . . 130 to 1
- Power Supply . . . . . Built-in 6-v, voltage-regulated (a-c power supply also available)
- Weight
  - Meter . . . . . 43½ lbs.
  - Antenna (including tripod) . . . . 15 lbs.
- Size . . . . . 19" L x 14½" H x 13" D

THE WX-1A meets the strict requirements of FM and TV engineers for a field-intensity meter of laboratory accuracy covering television, FM, and AM services between 50 and 220 Mc. Its high sensitivity permits minimum readings ranging from as low as 5 microvolts per meter at 50 Mc, to 20 microvolts per meter at 200 Mc.

Completely self-contained, the WX-1A includes a very stable superheterodyne receiver. Selectivity characteristic is down 65 to 1 on adjacent FM channels. Image ratio is 130 to 1 at 100 Mc. A 2-stage audio amplifier drives a built-in loudspeaker for continuous audio monitoring of the signals being measured.

Separate output terminals provide for convenient use with the standard Easterline-Angus recorder. The built-in vibrator power supply includes its own voltage regulator. The antenna . . . furnished with each WX-1A...is adjustable for horizontal or vertical polarization.

For accurate data on the service area of any TV, FM, or AM station in the uhf—and for authoritative coverage information for FCC proof-of-performance—the WX-1A is second to none. Complete details are available from your RCA Broadcast Sales Engineer. Or from Dept. 191B, RCA Engineering Products, Camden, N. J.



**BROADCAST EQUIPMENT**  
**RADIO CORPORATION of AMERICA**  
**ENGINEERING PRODUCTS DEPARTMENT, CAMDEN, N.J.**

In Canada: RCA VICTOR Company Limited, Montreal

Unique grounded-grid r-f input circuit provides high receiver sensitivity, greater frequency stability, and simplified tuning.

Heavy-duty dynamotor equipped with cooling fins. Mounted near chassis center of gravity. Excellent balancing. No vibration, tearing effects, or undue strains.

Built-in filter reduces spurious emission to 1000 Mc.—and beyond. All spurious emissions and harmonics in the band down at least 85 db.

Convenient pin jacks provide easily accessible points for servicing and tuning.

Frequency stability is within 0.001% (without an oven); is within 0.0005% (with oven) between -22° and +140° F.

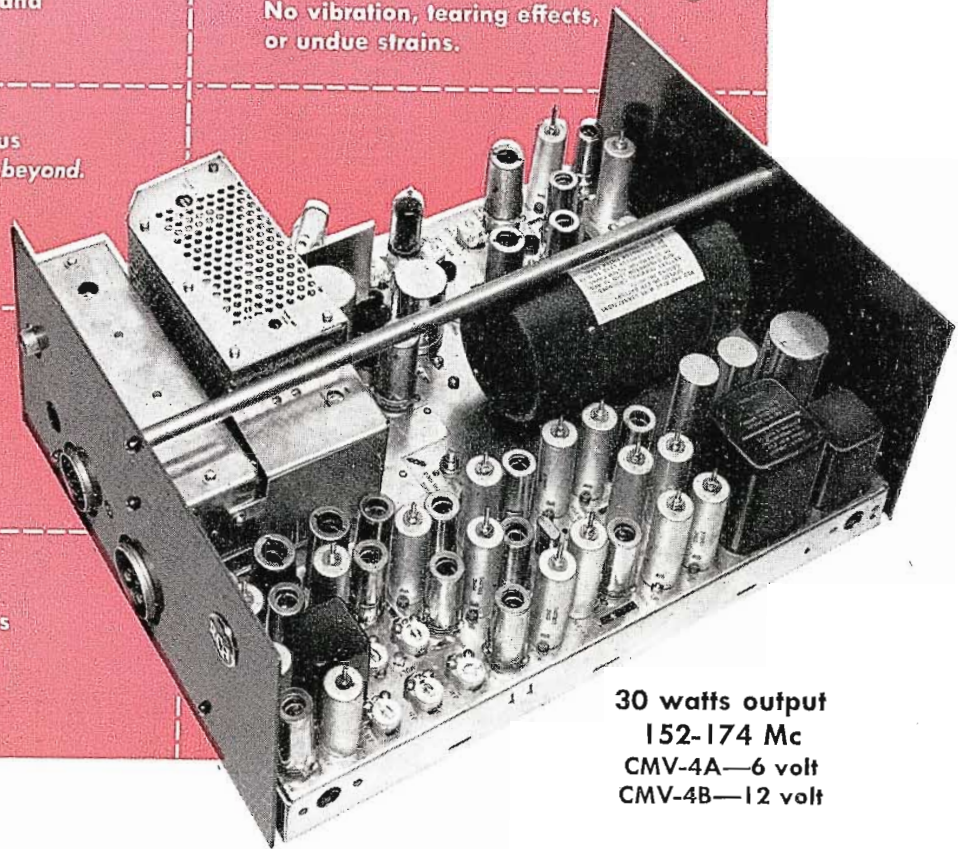

30 watts output  
152-174 Mc  
CMV-4A—6 volt  
CMV-4B—12 volt

## Now the 30-watt SUPER Carfone

A revolutionary new 2-way radio for police, fire fighting, public utilities, taxis, pipelines, and construction services

- ✓ Clear reception assured *within a few feet* of adjacent-channel stations because of superior circuit design.
  - ✓ Message intelligibility improved by raising average modulation to 70% (ordinary transmitters give 10 to 35%).
  - ✓ Spurious emissions at any frequency down at least 85 db (20 times better than required by FCC). Meets all RMA requirements.
  - ✓ Economical to operate (low current drain on stand-by; high-efficiency amplifier takes less power). Tubes are operated for optimum life; at least half of them idle at 1/5 of maximum rating.
  - ✓ Excellent performance in crowded metropolitan areas, as well as farther out in the suburbs where the going is tough.
  - ✓ Cuts down interference *within the band* at least 100 db (100 times better than required by FCC regulation).
  - ✓ Balanced construction reduces vibration—extends equipment life.
- The Super Carfone 30 package—(1) single-unit transmitter, receiver and power supply; (2) control box; (3) microphone and antenna; (4) speaker.

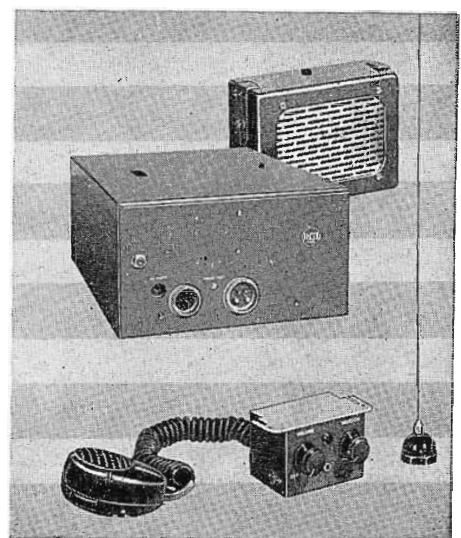

MOBILE COMMUNICATIONS SECTION  
**RADIO CORPORATION of AMERICA**  
ENGINEERING PRODUCTS DEPARTMENT, CAMDEN, N.J.

In Canada: RCA VICTOR Company Limited, Montreal



## FAITHFUL SERVANTS of AM Broadcasting

BY FAITHFULLY SERVING the important requirements of AM broadcasting, RCA tubes have won an unqualified reputation for engineering excellence, dependability, and true operating economy.

In the future, as in the past, AM broadcasters can look to RCA for the finest in power tubes. RCA consistently follows a program of developing new AM tube types and of improving earlier AM types. *For example:*

**RCA 892-R**—The forerunner of a group of RCA-designed air-cooled power amplifier tubes that simplified transmitter construction and introduced new operating and maintenance economies. Today, hundreds of these tubes are demonstrating their long life and dependability in the nation's leading 5- and 50-kw AM transmitters.

**RCA 833-A**—Originally designed by RCA engineers, this power triode features a giant zirconium-coated anode for greater dissipation, shielding that eliminates bulb bombardment, and a husky filament that has tremendous emission reserve for peak loads. These features have contributed to more dependable operation, longer service life, and greater operating economy.

**RCA 5671**—A recent addition to the RCA line, this power triode with its *thoriated-tungsten filament* draws 60 per cent less filament power than the previous pure-tungsten-filament type . . . making possible a saving of \$1200 or more a year in filament power in standard 50-kw AM transmitters. *Performance-proved* in the field.

✓ **A REMINDER**—RCA tubes for all types of broadcast service are available from your local RCA Tube Distributor or direct from RCA.

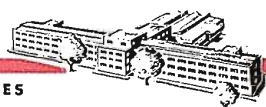

RCA LABORATORIES

PRINCETON, N. J.

THE FOUNTAINHEAD OF MODERN TUBE DEVELOPMENT IS RCA



**RADIO CORPORATION of AMERICA**  
ELECTRON TUBES  
HARRISON, N. J.